



ARCHON Industries, Inc.

357 Spook Rock Road, I-505

Suffern, NY 10901

Tel: (845) 368-3600

Fax: (845) 368-3040

www.ARCHONind.com

sales@ARCHONind.com

Sight Flow Indicators

150# ANSI Models

Model: **AKF-F – Flanged**
AKF-S – Threaded



Installation / Operation / Maintenance Instruction

Instruction No.:

Issued:

Approved:

1008.1 Rev C

10/13/23

Frank Bongiorno

Engineering Manager

| <u>TABLE OF CONTENTS</u> | PAGE |
|---|-------------|
| Product Warranty | 2 |
| 1.0 About the Manual | 2 |
| 2.0 Introduction | 2 |
| 2.1 System Description | 2 |
| 3.0 Available Models | 3 |
| 4.0 Installation | 3 |
| 4.1 Receiving Inspection | 3 |
| 4.2 Location Precautions | 3 |
| 4.3 Positioning of specific models..... | 3 |
| 4.4 Bolt torque | 4 |
| 5.0 Operation | 4 |
| 6.0 Maintenance | 4 |
| 6.1 Maintenance Procedures | 4 |
| 6.2 Troubleshooting | 5 |
| 7.0 Removal / Disassembly / Re-assembly | 5 |
| 7.1 Disassembly | 5 |
| 7.2 Reassembly | 5 |
| 8.0 Assistance | 5 |

TABLES AND FIGURES

| | | |
|----------|---------------------------|---|
| Table 1 | Bolt Torque Values | 4 |
| Figure 2 | Tightening Sequence | 4 |
| Table 3 | Parts List | 6 |
| Figure 4 | Assembly view | 6 |

PRODUCT WARRANTY

ARCHON Industries Inc., warrants its products as designed and manufactured by ARCHON to be free of defects in material and workmanship for a period of one year after the date of installation or eighteen months after the date of manufacture, whichever is earliest. ARCHON will, at its option, replace or repair any products that fail during the warranty period due to defective material or workmanship.

Prior to submitting any claim for warranty service, the owner must submit proof of purchase to ARCHON and obtain written authorization to return the product. Thereafter, the product shall be returned to ARCHON in Suffern, NY, with freight prepaid.

This warranty shall not apply if the product has been disassembled, tampered with, repaired or altered outside of the ARCHON factory, or if it has been subjected to misuse, neglect or accident.

ARCHON's responsibility hereunder is limited to repairing or replacing the product at its expense. ARCHON shall not be liable for loss, damage, or expenses directly or indirectly related to the installation or use of its products, or from any other cause or for consequential damages. It is expressly understood that ARCHON is not responsible for damage or injury caused to other products, building, property or persons, by reason of the installation or use of its products.

THIS IS ARCHON'S SOLE WARRANTY AND IN LIEU OF ALL OTHER WARRANTIES, EXPRESSED OR IMPLIED WHICH ARE HEREBY EXCLUDED, INCLUDING IN PARTICULAR ALL WARRANTIES OF MERCHANTABILITY OR FITNESS FOR A PARTICULAR PURPOSE.

This document and the warranty contained herein may not be modified and no other warranty, expressed or implied, shall be made by or on behalf of ARCHON unless modified or made in writing and signed by the President or a Vice President of ARCHON.

1.0 About the Manual

This manual has been prepared as an aid and guide for personnel involved in installation and maintenance. All instructions must be read and understood thoroughly before attempting any installation, operation or maintenance.

WARNING

Failure to follow instructions could result in breakage of the indicator, resulting in fluid escaping fragmenting glass. Always wear safety glasses when installing, servicing or operating a sight flow indicator. Failure to follow precautions can result in personal injury and property damage.

2.0 Introduction

ARCHON Industries, Inc.'s sight flow indicators are designed for observation of fluid flow in process lines. These sight windows are available in a variety of sizes, styles and connection methods. The user should refer to ARCHON literature to identify the specific sizes, models and connection types available.

A sight flow indicator permits the convenient monitoring of:

- fluid movement – change in direction or volume
- fluid color, tint or hue
- fluid clarity, opacity, brightness or purity

2.1 System Description

The ARCHON sight flow indicators consist of five basic components. Each component may vary slightly, depending on the exact model of the indicator.

Body - the main fitting containing piping connections and machined surfaces in which the glass and gasket are protectively seated.

Covers – these are bolted directly to the body. They have a machined surface in which the glass and the cushion are protectively seated.

Glass discs - the glass provides a window for fluid observation.

Gaskets - when the bolts are tightened properly, the seals are compressed between the glass and the body and cover to tightly seal the gap and prevent leaking.

Closure hardware – includes bolts for holding the cover.

3.0 Available Models

ARCHON offers the standard sight flow indicator in the following sizes and configurations:

AKF-FP – Plain Indicator / Flanged Body
AKF-FR – Rotator Indicator / Flanged Body
AKF-FF – Flapper Indicator / Flanged Body
AKF-FD – Drip Tube Indicator / Flanged Body

AKF-SP – Plain Indicator / Threaded Body
AKF-SR – Rotator Indicator / Threaded Body
AKF-SR – Flapper Indicator / Threaded Body
AKF-SR – Drip Tube Indicator / Threaded Body

4.0 Installation

Upon receipt of the ARCHON sight flow indicator, check all components carefully for damage which may have been incurred during shipping. **IMPORTANT: If damage is evident or suspected, do not attempt installation. Notify your carrier immediately and request a damage inspection.**

DANGER

Exceeding the design ratings or application's data limits can cause the glass to break, the unit to leak or sudden release of pressure. Do not exceed the design ratings for each particular unit. Failure to keep operating conditions below design ratings may result in severe personal injury and property damage.

CAUTION

Only qualified, experienced personnel who are familiar with sight window equipment and thoroughly understand the implications of the tables and all the instructions should install the hinged sight glass. Failure to read and comply with the following instructions could result in personal injury or property damage.

4.1 Receiving Inspection:

- 1) Examine the glass to see that it is free of scratches, chips or other imperfections.
- 2) Check all components carefully for damage that may have occurred during shipping. If damage is evident or suspected, do not attempt installation.

4.2 Location Precautions

Do not impose system piping loads on sight flow indicator. Unit is not designed to bear external piping loads or forces. Piping must be supported and aligned with sight flow indicator end connections to reduce the stresses imposed on the unit.

Locate the sight flow indicator:

- 1) where it can be easily seen;
- 2) away from areas where objects may be dropped thrown or generally allowed to contact the glass;
- 3) where it is protected from dust, grit or other objects that could damage the glass;
- 4) where it is protected from external thermal shock, such as a high temperature application being exposed to a cold air blast or cold water wash.

4.3 Positioning of Specific Models

- 1) Flapper models may be mounted in a horizontal plane provided the flapper closes over the inlet port by gravity when there is no flow.
- 2) Plain or rotator models may be mounted in any acceptable position.
- 3) Drip tube models should be mounted in a vertical plane with the flow arrow pointing downward.

4. Bolt Torque

Torquing under pressure yields incorrect torque and increases the likelihood of the glass disc breaking and contents spraying out of the unit. The sight flow indicator must be relieved of all pressure or vacuum, allowed to reach ambient temperature and drained or purged of all fluids before re-torquing. Failure to follow this procedure could result in severe personal injury and property damage.

Bolt torque is vital to the proper operation of a sight flow indicator. Gaskets compress over a period of time, therefore, bolt torque should be checked, and bolt torque values should be brought up to those recommended in Table 1 by following the bolt tightening sequence shown in Figure 2.

Bolt Torque Values (ft / lb)

| Unit Size | Gasket Material | |
|----------------------|------------------------------------|---|
| | Elastomers (Neoprene, Viton) | Fiber, Non- Asbestos, Grafoil, Exp PTFE) |
| 1/2" & 3/4" | 2 - 3 | 5 - 7 |
| 1" | 2 - 3 | 5 - 7 |
| 1 1/2" | 3 - 5 | 8 - 11 |
| 2" | 10 - 15 | 27 - 36 |
| 2 1/2" & 3" | 13 - 21 | 38 - 50 |
| 4" | 16 - 25 | 45 - 60 |
| 6" (4-BOLT COVER) | 50 - 75 | 130 - 190 |
| 6" (8-BOLT COVER) | 18 - 30 | 52 - 75 |

Table 1

Tightening Sequence

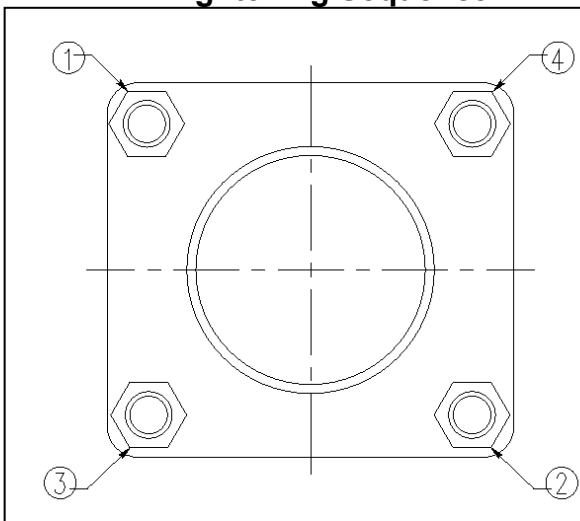

Figure 2

5.0 Operation

- 1) Before initializing sight window operation, check that all installation procedures have been completed.
- 2) Check that bolts have been torqued to their proper limits.
- 3) Check that glass is clean and free of any damage.
- 4) Check to determine that all connections are pressure tight.

DANGER

Sight flow indicator should be brought into service slowly to avoid excessive shock or stress on the glass. Rapid pressurization of a

sight flow indicator can cause glass breakage/fragmentation and fluid leakage. Failure to take proper precautions could result in severe personal or property damage.

6.0 Maintenance

Use only qualified experienced personnel who are familiar with sight window equipment and thoroughly understand the implications of the tables and all the instructions.

Create a maintenance schedule for each specific installation of a sight flow indicator. On all inspections, regularly check the following items:

- 1) glass for cleanliness and signs of damage or wear,
- 2) sight window for signs of leakage at gaskets or along welds,
- 3) sight window for signs of internal or external corrosion, and
- 4) closure bolt tightness

Use only qualified experienced personnel who are familiar with sight window equipment and thoroughly understand the implications of the tables and all the instructions.

6.1 Maintenance Procedures

GLASS should be given regular and careful attention. Keep glass clean using a commercial glass cleaner and a soft cloth. Inspect the surface of the glass for any clouding, etching or scratching or physical damage such as bruises checks or corrosion. Glass that is damaged is weakened and may break under pressure. Shining a light at approximately a 45° angle will aid in detecting some of these conditions. Typical damaged areas will glisten more brightly than the surrounding glass because the light is reflected.

Detection of any damage, problem areas or surface wear is sufficient evidence to take the sight window out of service. DO NOT proceed with operations until the glass has been replaced with a glass replacement kit following the assembly instructions in Section 4.

GASKET LEAKS must be repaired immediately. DO NOT proceed with operations until gaskets have been replaced.

6.2 Troubleshooting

Problem: glass or shield becomes etched or clouded in service

Cause: fluid being handled is not compatible with the glass or shield material

Solution: replace the glass and/or shield

Problem: glass continually breaks in service

Cause: warped body as a result of mechanical or thermal stresses

Solution: reduce the stress and replace sight window.

7.0 Removal/Disassembly/Reassembly

DANGER

DO NOT proceed with the removal or disassembly of sight flow indicator from the connecting piping unless sight flow indicator has been relieved of all pressure or vacuum, has been allowed to reach ambient temperature, and has been drained or purged of all fluids. Failure to do so can cause serious personal injury to personnel.

7.1 Disassembly

A. Sight flow indicators should be disassembled by holding sight flow indicator firmly and loosening bolts by the opposite of the tightening sequence shown in Figure 1.

7.2 Reassembly

A. Refer to exploded view, Figure 5.

B. Prepare for installation of new glass (48) by first cleaning the gasket seating surfaces on body (11) and the cushion seating surfaces on the glass covers (1). This should be done using a soft metal scraper (preferably brass) to remove all burrs, rust, and bits of old gasket or cushion which may be present. Exercise extreme care to avoid gouging or scarring gasket or cushion seating surfaces.

C. Upon receipt of glass, inspect each piece individually for shipping damage. During inspection, and during any subsequent handling of glass, care must be exercised to keep glass (especially the polished faces) from contacting each other or any other surfaces including table tops. If shipping damage is evident or suspected, notify carrier immediately and request a damage inspection. Glass should be kept in original wrap within original box until ready to use.

D. Place the sight flow indicator in a horizontal position and assemble the components as shown in exploded view Figure 5.

E. Threads on bolts (137) and nuts (4) must be clean of paint, rust, and scale. Apply a light coat of

oil to the threads and insert bolts through nameplate and two (2) covers, and install nuts finger tight.

F. Use a torque wrench to tighten the bolts. Tighten bolts in increments of 5 ft./lbs. or 50% of torque value as shown in Table 1, whichever is smaller. Continue tightening sequence until torque values are reached.

G. Gaskets will become compressed a short time after bolts are tightened and torque values will decrease. Therefore, the sight flow indicator must be re-torque after 24 hours in service to values established within table 1 for the specific model sight flow indicator.

DANGER

Once sight flow indicator has been disassembled, all glass, gaskets, cushions, and shields (where used) must be disposed of since they are permanently deformed by compression. DO NOT under any circumstances re-use those items since they can cause leaks or high stress points resulting in glass breakage. If re-used, the glass can break causing serious personal injury to personnel.

8.0 Telephone Assistance & Equipment Return

If you are having difficulty with your Sight flow indicator, notify your local ARCHON distributor, or call the factory direct **(845) 368-3600** or email **sales@archonind.com**. To help us assist you more effectively, please have as much of the following information as possible when you call:

- Model #
- Name of the company from whom you purchased the sight flow indicator
- Invoice # and Date
- Process Media
- Operating Temperature
- Operating Pressure
- Brief description of the problem

You must obtain a Return Authorization (RA) number from ARCHON before returning anything. To obtain a RA#, the following information (in addition to that above) is needed:

- Reason for Return
- Person to contact at your company
- "Ship-To" address

There is a minimum charge of \$50.00 for evaluation of non-warranty units. You will be contacted before we repair the unit if there will be any additional charges. If you return a unit that is covered by the warranty, but is not defective, the minimum charge will apply

| Parts List | | |
|------------|---------------|----------------------------|
| Item | Description | Recommended Spare Quantity |
| 1 | Body | 0 |
| 2 | Cover | 0 |
| 3 | Lens | 2 |
| 4 | Gasket | 2 |
| 5 | Cushion | 2 |
| 6 | Bolt | 0 |
| 7 | Pin | 0 |
| 8 | Rotator | 0 |
| 9 | Spacer, Front | 0 |
| 10 | Spacer, Mid | 0 |
| 11 | Spacer, Back | 0 |
| 12 | Flapper | 0 |

Table 3

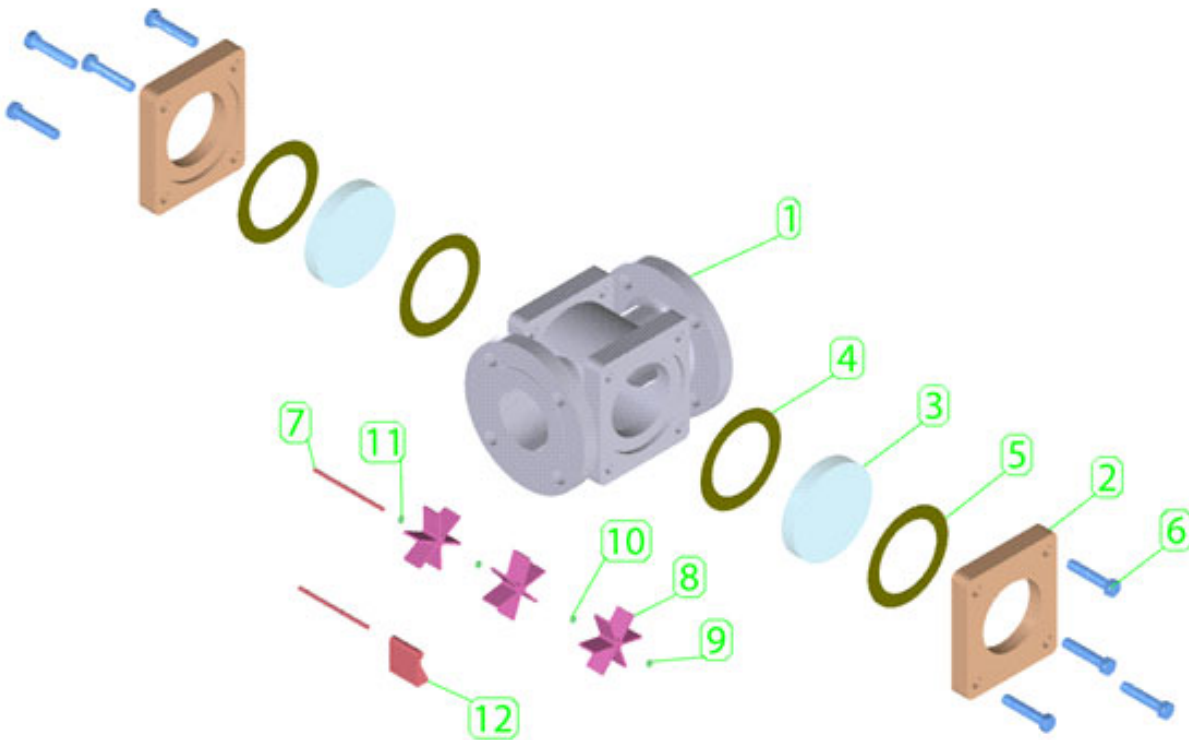

Figure 4