

2

1

REVISIONS				
REV	DESCRIPTION	DATE	DRAWN	APPROVED
A	INITIAL RELEASE	01/13/17	J.CUSTY	
B	ADDED SHEET 2	02/12/25	JF	

ARCHON P/N	SUPPLIED W/BRACKETS
EX99-LED01	1-1/2"
EX99-LED02	3"
EX99-LED03	4"

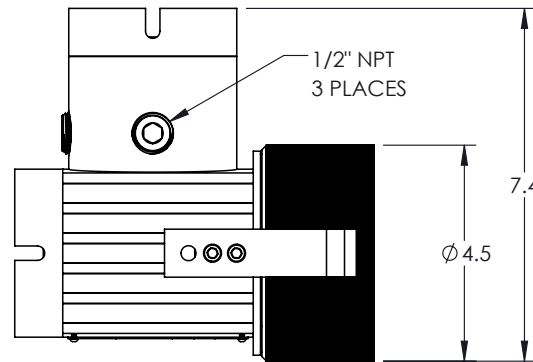
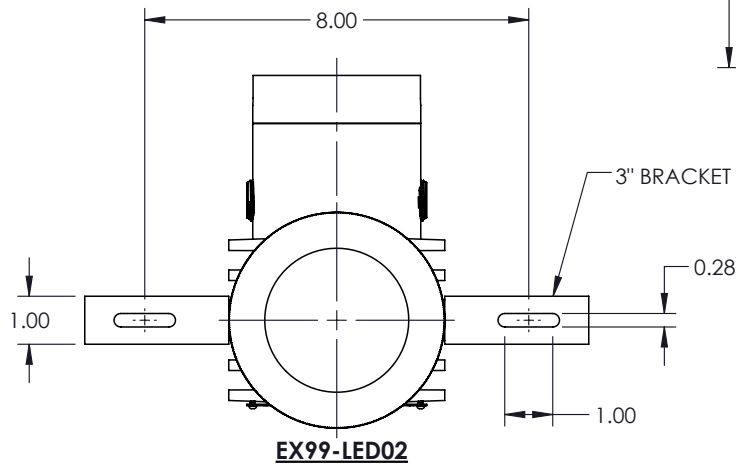
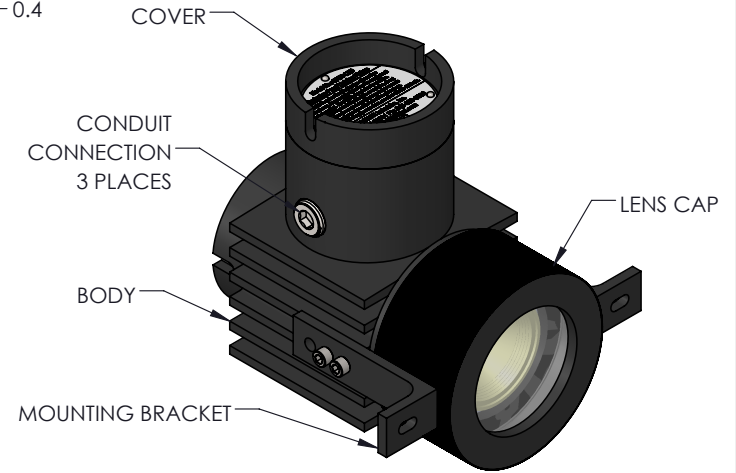
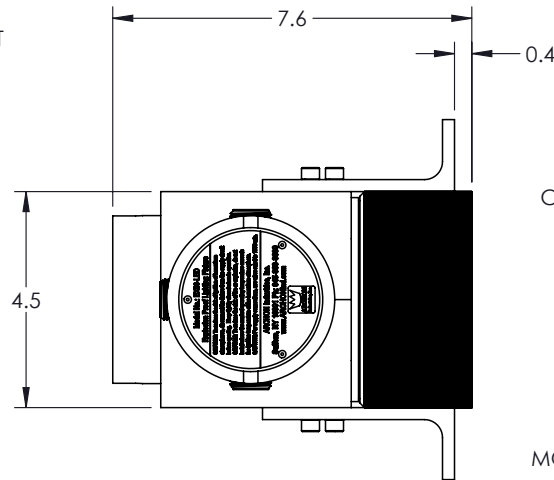
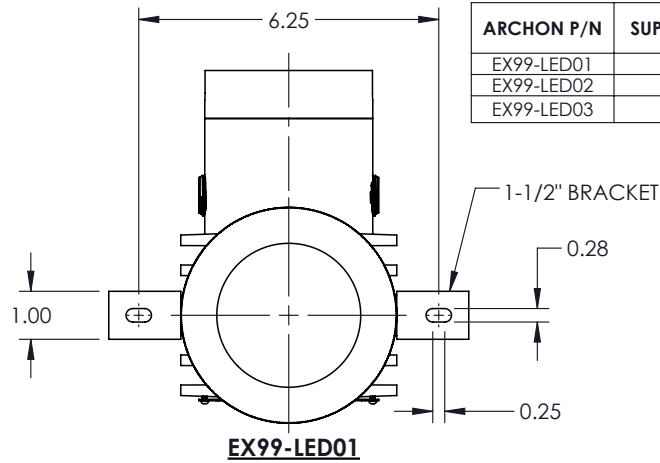

**SPECIFICATIONS:**  
 MANUFACTURER: ARCHON INDUSTRIES, INC.  
 MODEL: EX99-LED (UL CONTROL NO. 3R75)  
 RATING: CLASS 1, DIV 1&2, GROUP C&D  
 INPUT: 120-277 VAC / 14.7W / 50-60 HZ  
 COB LED 31.5 - 42 VDC / 350 ma DC  
 WIRE RATING: 105°C (MIN SUPPLY CONN.)  
 TEMP CODE: T6  
 MAX AMBIENT TEMP: 40°C  
 LUMEN OUTPUT: ~1350

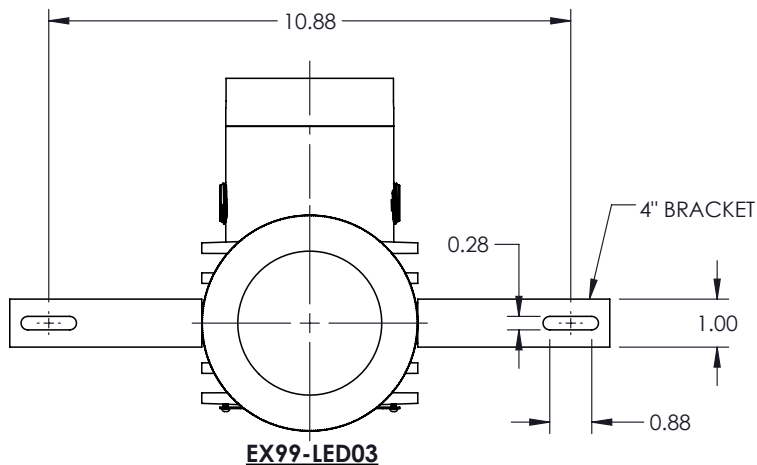

UNLESS OTHERWISE SPECIFIED	DR	JPC	DATE	1/12/17
DIMENSIONS IN INCHES	CHKD		DATE	
DECIMALS	APVD		DATE	
FRACTIONS	APVD		DATE	
X ± .030				
XX ± .015				
XXX ± .010				
ANGLES				
±.5				
REMOVE ALL BURRS AND BREAK SHARP EDGES .02 MAX	MATERIAL:			
SURFACE ROUGHNESS ✓	FINISH:			
DIMENSIONS AFTER PLATING OR COATING	WEIGHT: 10 LBS (APPROX.)			
THIRD ANGLE PROJECTION	DO NOT SCALE DRAWING			

**ARCHON INDUSTRIES, INC.**  
 357 SPOOK ROCK ROAD  
 SUFFERN, NY 10901  
 (845) 368-3600  
 FAX (845) 368-3040

TITLE:		LUMINAIRE EXPLOSION PROOF EX99-LED	
SIZE	SCALE:	SHEET 1 OF 1	
<b>A</b>	DWG. NO.	EX99-LED-ASM	REV <b>B</b>

2

1

2

1

ARCHON P/N	SUPPLIED W/ADAPTER
EX99-LED06	2"
EX99-LED05	3"
EX99-LED04	4"

**NOTE:**  
ADAPTER ASSEMBLY IS SUPPLIED WITH EPDM CUSHION GASKET AND TEMPERED BOROSILICATE WINDOW. TRI-CLAMP GASKET AND CLAMP TO BE SUPPLIED BY CUSTOMER.

REVISIONS				
REV	DESCRIPTION	DATE	DRAWN	APPROVED
A	INITIAL RELEASE	08/14/19	J.CUSTY	
B	ADDED CUSHION AND LENS CALLOUT	02/13/25	JF	



4" TC ADAPTER

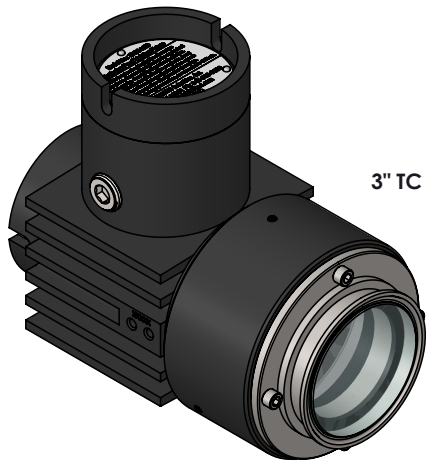

3" TC ADAPTER

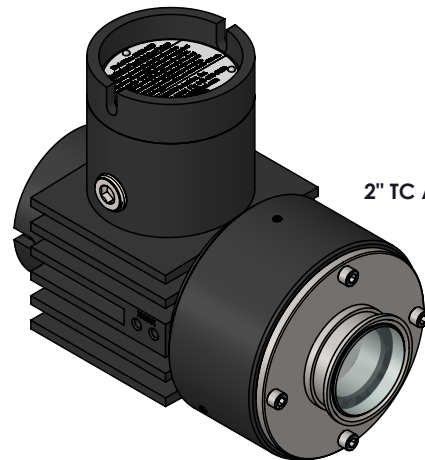

2" TC ADAPTER

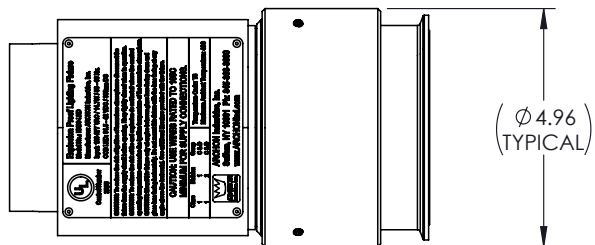
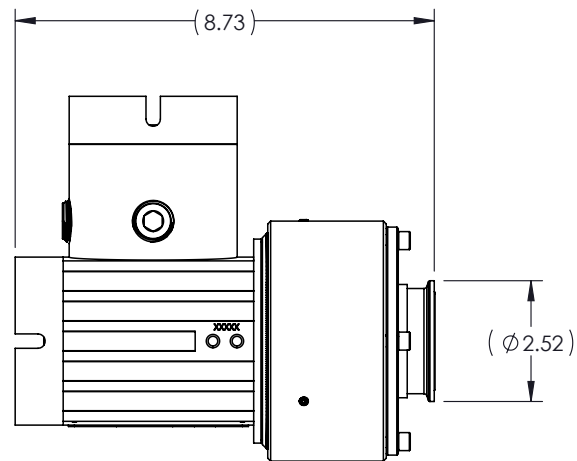
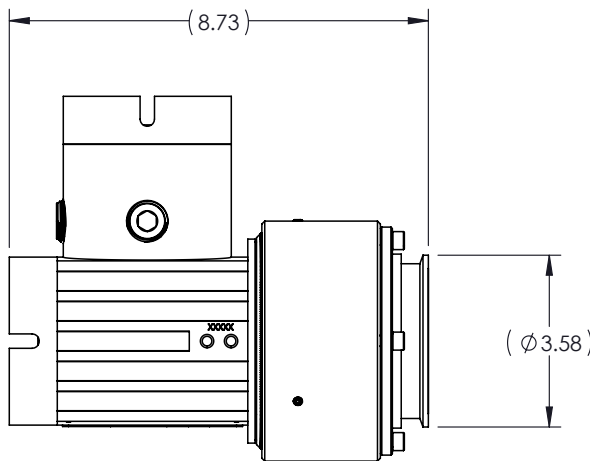
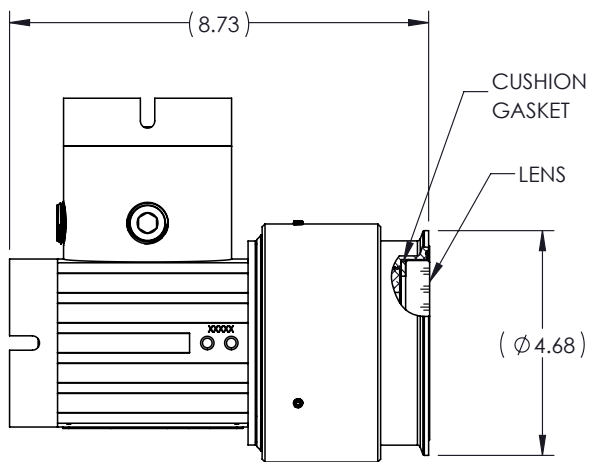

UNLESS OTHERWISE SPECIFIED	DR	JPC	DATE	08/14/19
DIMENSIONS IN INCHES	CHKD		DATE	
DECIMALS	APVD		DATE	
FRACTIONS	APVD		DATE	
X ± .030				
XX ± .015				
XXX ± .010				
± 1/64				
ANGLES				
± .5				
REMOVE ALL BURRS AND BREAK SHARP EDGES .02 MAX	MATERIAL:			
SURFACE ROUGHNESS ✓	FINISH:			
DIMENSIONS AFTER PLATING OR COATING	WEIGHT: 10 LBS (APPROX.)			
THIRD ANGLE PROJECTION	DO NOT SCALE DRAWING			

 <b>ARCHON</b> INDUSTRIES, INC.	357 SPOOK ROCK ROAD SUFFERN, NY 10901 (845) 368-3600 FAX (845) 368-3040		
	<b>TITLE:</b> LUMINAIRE EXPLOSION PROOF EX99-LED (TRI-CLAMP)		
<b>SIZE</b> <b>A</b>	<b>SCALE:</b> DWG. NO. EX99-LED-ASM	SHEET 1 OF 1 REV <b>B</b>	

2

1