



## MODEL SS - SANITARY SIGHT GLASS

### Description:

Model SS sight glasses are designed for process observation in pharmaceutical, food, beverage, dairy and general processing industry. They are also widely used in distillation columns. They are available in various materials of construction, and are for use in vacuum and pressure applications.

### Operating conditions:

Standard units are designed for full vacuum and 85 psig pressure. Maximum temperature rating is 500°F, but this may be limited by the gasket material and/or lens material selected.

### Options and accessories:

SS sight glasses can be supplied with either inch or metric sized welding ferrules. The following options and accessories are available:

- Lighting units for non-hazardous locations
- Low pressure wipers
- Various types of welding ferrules

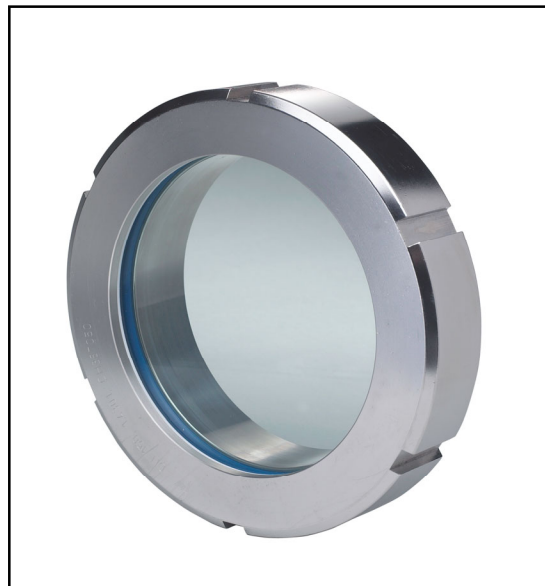

Model	"DN" (Metric models)	"DN" (Inch models)	"D"	"B" (Metric models)	"B" (Inch models)	"A"	"C"
SS-050	50 mm	1.87"	3.6"	53 mm	2.0"	1.8"	0.7"
SS-065	66 mm	2.37"	4.4"	70 mm	2.5"	1.9"	0.9"
SS-080	81 mm	2.87"	5.0"	85 mm	3.0"	2.1"	0.9"
SS-100	100 mm	3.83"	5.8"	104 mm	4.0"	2.6"	1.3"
SS-125	125 mm	NA	7.0"	129 mm	NA	2.4"	0.8"
SS-150	150 mm	NA	8.3"	154 mm	NA	2.4"	0.6"

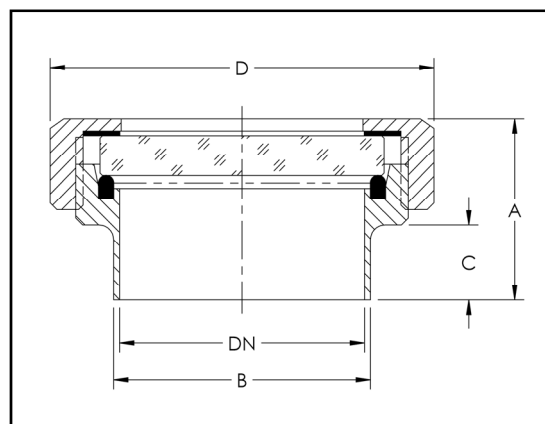

### Ordering Information:\*

Model: SS —

<b>Size:</b>	<b>Weld Ferrule</b>	<b>Weld Ferrule Type:</b>	<b>Cushion Gasket:</b>	<b>Seal Gasket:</b>	<b>Lens:</b>	<b>Accessories:</b>
050: 2.0"	<b>Material:</b>	M: Metric Standard Wall	04: PTFE	02: EPDM	A: Borosilicate	C: Wiper
065: 2.5"	B: 304 SS	H: Metric Heavy Wall		03: Buna-N	D: Polycarbonate	E: Light mounting
080: 3.0"	C: 316 SS	I: Inch Standard Wall		04: PTFE	E: Acrylic	
100: 4.0"	0: None	0: None		09: Viton®		
125: 5.0"				15: Silicone		
150: 6.0"						

\*Contact ARCHON for additional material options, temperature ratings or special configurations.