



# ARCHON

[www.ARCHONind.com](http://www.ARCHONind.com)



SPRAY NOZZLES

HOSE REELS

HOSE ASSEMBLIES

HOSE FITTINGS

WASHDOWN STATIONS

**WASHDOWN EQUIPMENT FOR THE PROCESSING INDUSTRY**



## ABOUT US

Incorporated in 1993 and headquartered in Suffern, NY, ARCHON Industries, Inc. has fast become a global leader in its field. Specializing in the manufacturing and distribution of quality equipment to the processing industry, ARCHON has earned a reputation for supplying high quality products and engineered solutions, while maintaining quick and professional service standards to all their valued customers. ARCHON offers a wide variety of mechanical equipment, and is a leading supplier of products associated with pharmaceutical, chemical, petrochemical, biotechnology, food processing, beverage, power, dairy and pulp & paper.

Our washdown equipment, manufactured and assembled in Suffern, NY is an integral part of ARCHON Industries. The ARCHON Steam and Water Mixing Unit, model WD2010, is one of our signature products. While maintaining its simplistic design and ease of use, it offers its users uncompromised reliability and safety. With few moving parts and a wide range of operating capabilities, this unit has proven to be unrivaled as the leader in the industry. Capable of handling 200 psig of steam, no other unit in the market even comes close.

In our extensive catalog, you will find all the resources available to you for washdown cleaning, including; Steam and Water Mixing Units, Hot and Cold Water Mixing Units, Thermostatically Controlled Mixing Units, Hoses, Reels, Spray Guns and much more. If you have any questions, or require assistance with a unique application, our engineering staff is always available to help with design and product selection. We look forward to becoming an integral part of your processing facility.



## TABLE OF CONTENTS

STEAM & WATER MIXING STATIONS	4 - 5
HOT & COLD WATER MIXING STATIONS	6 - 7
SINGLE VALVE HOSE STATIONS	8
STAINLESS STEEL ENCLOSURES	9
MOUNTING PLATES & HOSE RACKS	10
WASHDOWN HOSE	11
SPRAY NOZZLES	12 - 14
HOSE REELS	15 - 17
SWIVEL ADAPTERS	18

## TRUSTED BRANDS, WHO TRUST ARCHON INDUSTRIES







## STEAM AND WATER MIXING STATIONS



ARCHON Washdown Stations are simple and easy to use and are engineered for maximum SAFETY.

Steam and cold water are carefully and thoroughly mixed to provide "instant" hot water on demand. Using the proportional flow water and steam control valves, the operator can adjust the washdown station to deliver the desired hot water temperature as indicated on the dial thermometer located in the mixed water discharge.

### Features

- Safety valve shuts steam supply off if water pressure drops
- Designed to reduce carbonate or mineral build-up at steam inlet valve
- Manually operated flow proportioning control valves
- Internal steam and water check valves to prevent backflow
- Integral steam-water venturi mixer for consistent mixing
- Outlet liquid temperature indicating dial gauge
- Simple wall mounting design for easy installation
- Stainless steel hose rack for convenient hose storage

### Operating conditions

All units have a maximum allowable pressure of 200 psig steam. See table for recommend supply pressure.

Water supply pressure up to 150 psig.

### Materials

Body castings: ASTM B61 Bronze or 316 Stainless Steel.

Seals: PTFE and EPDM.

### Connections

Inlet and outlet connections: 3/4" NPT female.

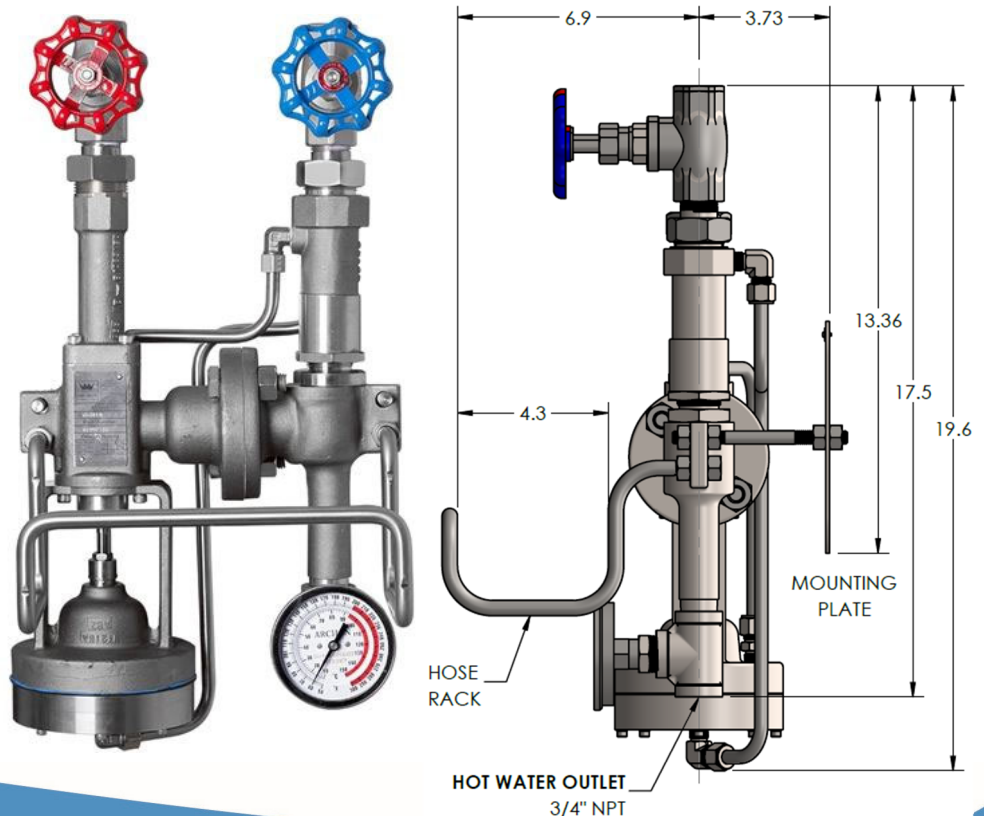



Model	Water Pressure psig	Recommended Steam Pressure psig	Maximum recommended discharge temperature	Outlet flow rate gmp
WD2010-XX-100	30-150	20-60	190°F	2.5-4.5
WD2010-XX-500	40-150	50-150	190°F	4.5-8.5
WD2010-XX-900	50-150	150-200	190°F	6.0-9.0

**XX = BR for Bronze. XX = SS for 316 Stainless Steel**

Contact ARCHON for additional material options, temperature ratings or special configurations.

**MINIMAL MAINTENANCE REQUIRED!**

Carbonate build-up at the steam inlet valve, a problem plaguing competitive units, is minimized. A check valve is optimally positioned within the mixing station between the steam inlet valve and the cold water chamber housing the specially designed steam-water venturi mixer. The steam valve seat is isolated from the cold water supply, preventing deposit of carbonates at the steam valve thus reducing the potential for steam inlet valve seizure. No special tool kits are required for the ARCHON washdown station to operate at maximum efficiency and safety.

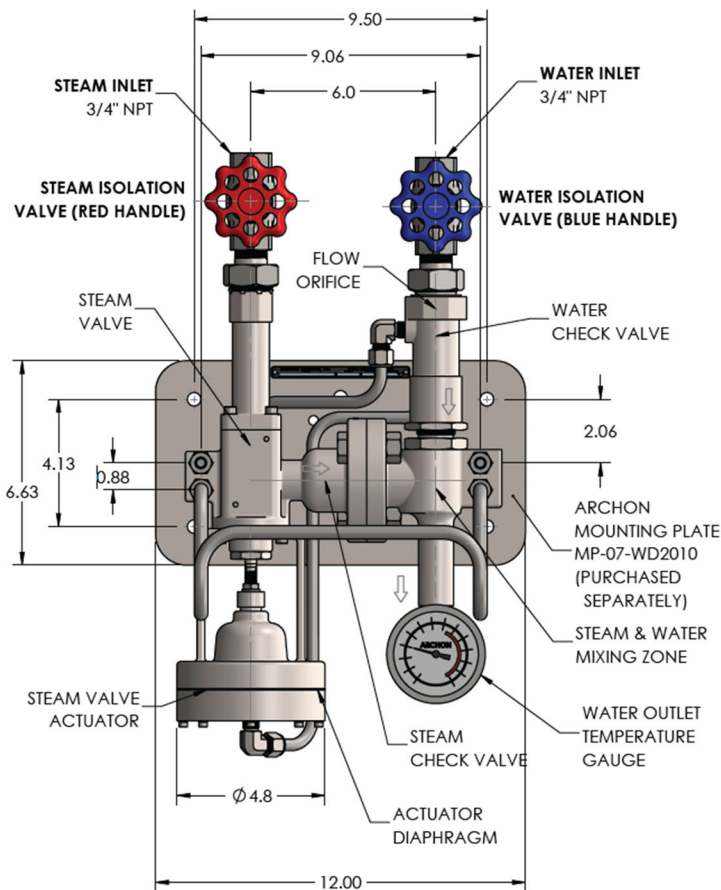

**SAFETY FIRST!**

When handling live steam, SAFETY COMES FIRST! To reduce the potential for steam discharge, all ARCHON steam and water mixing stations employ a unique valve and diaphragm technology. Steam is automatically blocked from discharging from the mixing station using a specially engineered diaphragm device. The diaphragm uses the steam supply pressure to positively close the steam inlet valve to the mixing chamber. The mixing station does not rely on potentially unreliable components such as temperature sensors or electrical devices to keep the steam valve closed. The diaphragm device will permit the steam inlet valve to open only after sufficient cold water flow is established by squeezing the spray nozzle or lance. If at any time the cold water is restricted, the steam is automatically shut off. NO WATER - NO STEAM!



## HOT AND COLD WATER MIXING STATIONS

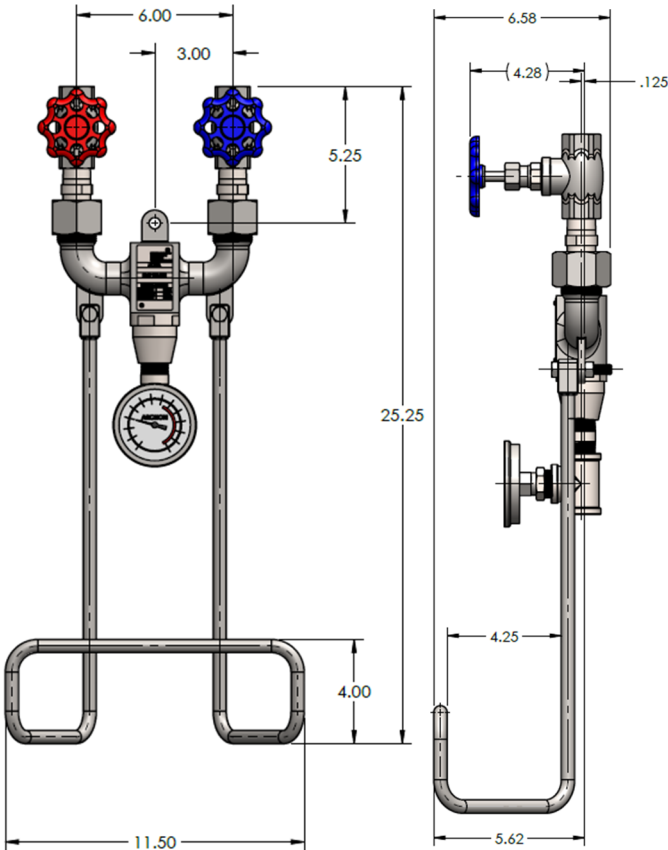

ARCHON Mixing Stations have been engineered for maximum reliability and operator safety. Using the proportional flow water control valves, the operator can adjust the mixing station to deliver the desired hot water temperature as indicated on the dial thermometer located in the mixed water discharge. ARCHON mixing stations are widely used in dairy, pharmaceutical, food processing, chemical and industrial plants.

### Features and Benefits

- Easily maintained
- No special tool kits needed
- Manually operated flow proportioning control valves
- Check valves provided on both the hot and cold water connections to prevent back-flow
- Outlet liquid temperature indicating dial gauge
- Simple wall mounting design for easy installation
- Stainless steel hose rack for convenient hose storage

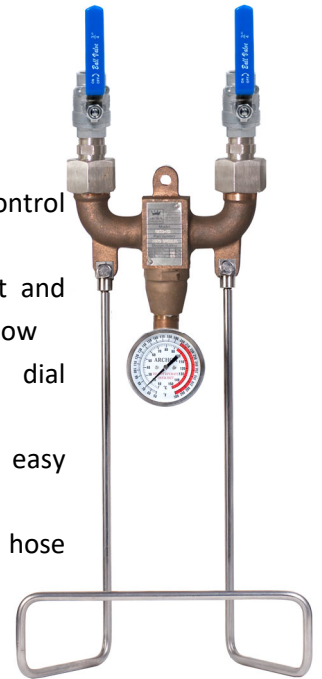

### Operating conditions

All units have a maximum allowable pressure of 125 psig.

### Materials

Body castings: C87600 "Lead-free" Bronze or CF8M 316 SS.

Seals: PTFE and Viton

### Connections:

Inlet and outlet connections:

3/4" NPT female

Ordering Code	Description
HCMX-BR	Bronze with globe valves
HCMX-SS	Stainless steel with globe valves
HCMX-BR-BV	Bronze with ball valves
HCMX-SS-BV	Stainless steel with ball valves

Recommended Water Pressure psig	Maximum recommended discharge temperature	Outlet flow rate gpm
30-125	200°F	2.5-11

## THERMOSTATICALLY CONTROLLED HOT AND COLD WATER MIXING STATIONS

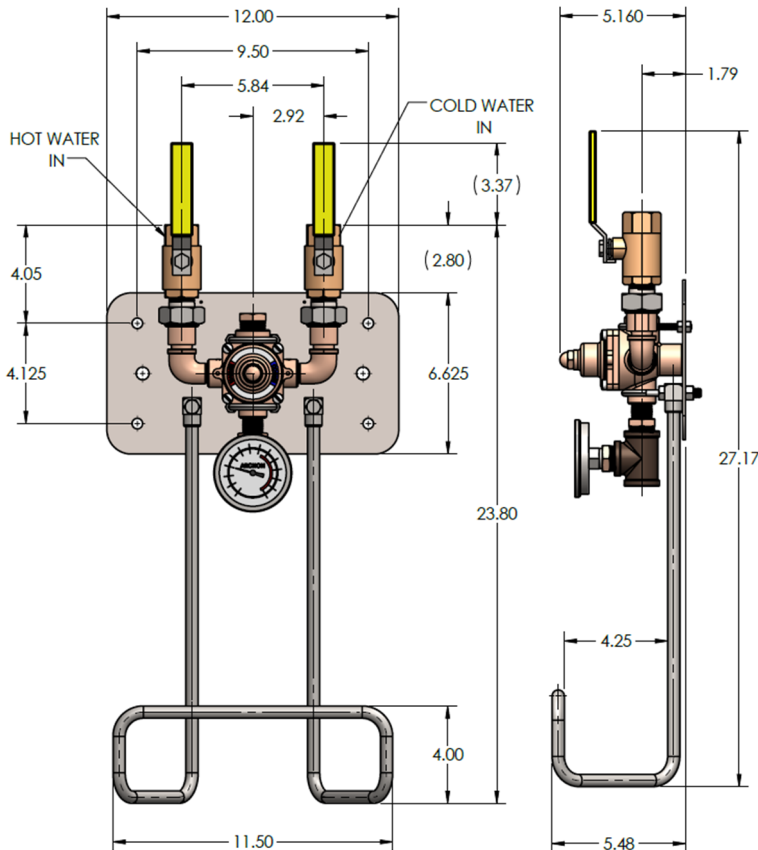

ARCHON Thermostatically Controlled Mixing Station (Model **HCMXTC-BR**) is a thermostatically controlled mixing valve assembly that delivers constant temperature water. It automatically compensates for fluctuations in incoming hot and cold water temperature and/or pressure.

A liquid filled thermostat and a lead-free brass control valve guard against unexpected hot or cold water spikes and proportion the water flow to maintain a constant outlet temperature  $\pm 3^{\circ}\text{F}$  over the range of  $80^{\circ}\text{F}$  to  $160^{\circ}\text{F}$  for up to 10 gallons per minute at a differential pressure of 40 psi, with a maximum hot water supply of  $180^{\circ}\text{F}$ .

Mixed water temperature is adjusted by turning a set-screw and is indicated on a dial thermometer. The housing is brass and the wetted parts are brass, stainless steel, PTFE and buna rubber.

The assembly includes an inlet shut-off valve and a check valve with  $3/4$ " NPT union connection on both the hot and cold water legs.

### Features

- Accurate control of temperature from  $80^{\circ}\text{F}$  to  $160^{\circ}\text{F}$ .
- Maintains temperature to  $\pm 3^{\circ}\text{F}$ .
- Maximum water temperature of  $160^{\circ}\text{F}$ .
- Adjustable temperature limit stop for safety.
- Self adjusts for temperature or pressure variations.
- Maximum working pressure to 125 psi.
- Color coded temperature dial.
- Brass body with replaceable corrosion-resistant components.
- Stainless steel piston and liner.
- Brass and Stainless Steel construction.
- $3/4$ " high flow unit 10-12 gpm standard.

### Thermostat

Automatically responds to temperature and pressure variations in hot and cold water lines.

The stainless steel piston and liner precisely proportion water flow to maintain a constant outlet temperature and to guard against unexpected hot or cold water spikes.



## SINGLE VALVE HOSE STATIONS

ARCHON model **WDB-92** is a simple, economical unit made of stainless steel and ideal for Hot or Cold water service.

The unit includes a Ball Valve, Hose Rack and Mounting Bracket.

### Features

- 3/4" Full Port 316SS Ball Valve
- Stainless Steel Hose Rack
- Stainless Steel Mounting Bracket
- Maximum working pressure to 150 psig
- Maximum working temperature to 200°F

### Optional

- 1/2" Full Port 316SS Ball Valves (Model **WDB-92.5**)

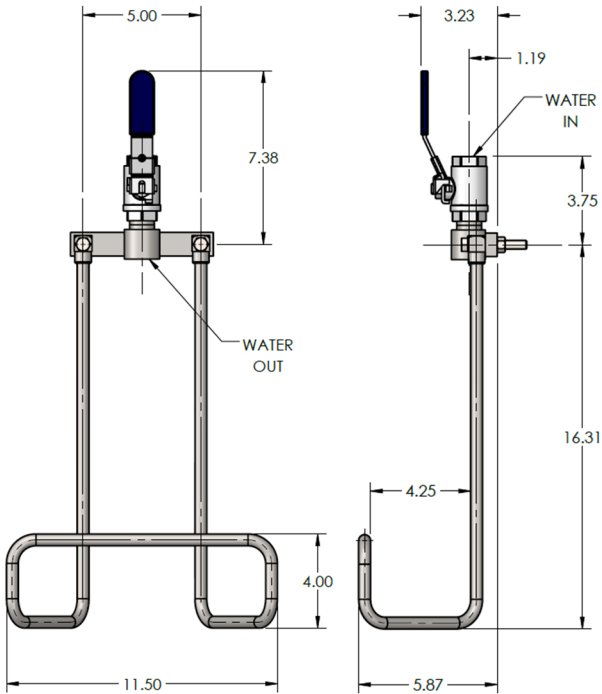

ARCHON model **WDG-94** is a single globe valve unit for Hot or Cold water service.

The unit includes a Globe Valve, Hose Rack and Mounting Bracket.

### Features

- 3/4" 316SS Globe Valve
- Stainless Steel Hose Rack
- Stainless Steel Mounting Bracket
- Maximum working pressure to 150 psig
- Maximum working temperature to 200°F

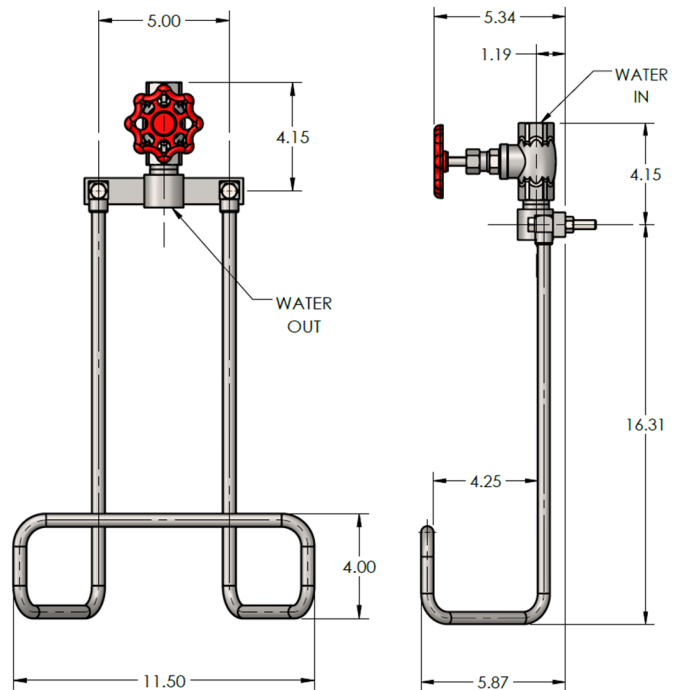





## STAINLESS STEEL ENCLOSURES



ARCHON's stainless steel cabinets are designed to house our WD2010 and HCMX cleaning stations. Our stainless steel enclosures are used in the food and dairy industries. Available with USDA approval and criteria to meet 3A SSI Standards.

Our industrial enclosures are fabricated out of heavier gauge materials for higher reliability, quality, and durability, and our sloped top options offer increased sanitation when used in wet and corrosive environments.

Our high quality cabinets are available in styles to completely house the washdown station, hose rack, hose and spray nozzle.

Height (H)	Width (W)	Depth (D)	Sub Panel Height (X)	Sub Panel Width (Y)
36	24	12	33	21

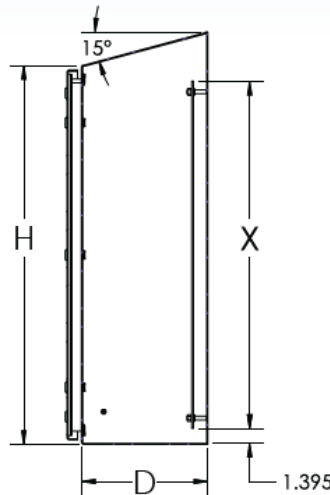
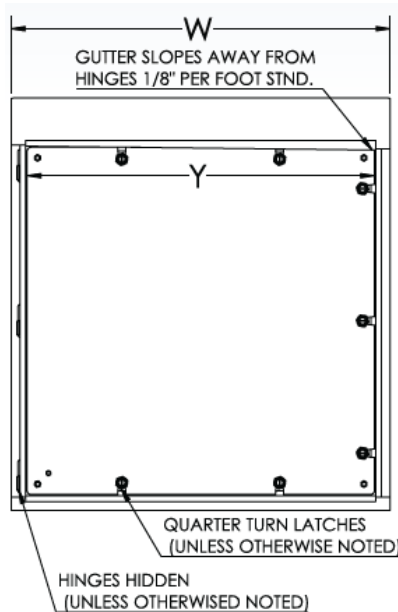



## MOUNTING PLATES AND HOSE RACKS



### HR-07 Stainless Steel Hose Rack

A standard feature on all of our hot and cold water mixing units, the stainless steel hose rack is also sold separately for individual hose mounting needs.

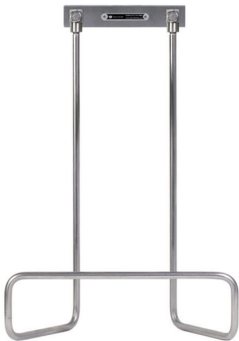

### HR-08 Stainless Steel Hose Rack

The ARCHON stainless steel hose rack features a mounting bar for independent wall mounting



### MP-07 Stainless Steel Mounting Plate

Stainless steel mounting plates used on our hot and cold water mixing units can also be purchased separately as required.



### HRMP-08 Stainless Steel Hose Rack and Mounting Plate

Stainless steel mounting plate and hose rack are standard supplied equipment with all ARCHON wall mounted hot and cold water mixing units.



## WASHDOWN HOSE

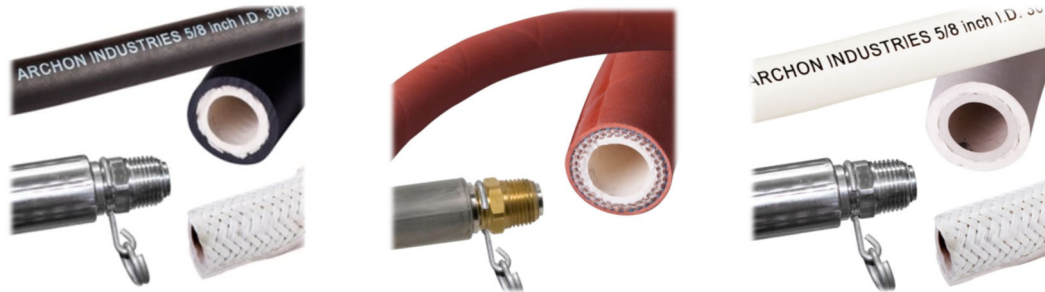

	Standard 5/8" Hose	Premium Wrapped 5/8" Hose	3/4" Hose
Cover	Smooth Extruded Rubber	Wrapped Rubber	EPDM Synthetic Rubber
Inner Tube	FDA White Nitrile	FDA IIR Rubber	EPDM Synthetic Rubber
Temperature	200°F	200°F	200°F White/210°F Red
Pressure	300 psig	300 psig	300 psig

HOSE WITH BRASS END FITTINGS	
Ordering Code	Hose Color
<b>STANDARD 5/8" HOSE ASSEMBLY</b>	
45783-XXX	White
45785-XXX	Black
<b>PREMIUM WRAPPED 5/8" HOSE ASSEMBLY</b>	
45786-XXX	White
45787-XXX	Red
45788-XXX	Black
<b>3/4" HOSE ASSEMBLY</b>	
45774-XXX	White
45781-XXX	Red

HOSE WITH SS END FITTINGS	
Ordering Code	Hose Color
<b>STANDARD 5/8" HOSE ASSEMBLY</b>	
45783-XXX-SS	White
45785-XXX-SS	Black
<b>PREMIUM WRAPPED 5/8" HOSE ASSEMBLY</b>	
45786-XXX-SS	White
45787-XXX-SS	Red
45788-XXX-SS	Black
<b>3/4" HOSE ASSEMBLY</b>	
45774-XXX-SS	White
45781-XXX-SS	Red

XXX=Hose Length

Example: 025 is 25' Long



## SPRAY NOZZLES



### Rear Trigger - Model RT12

Available in Bronze and 304SS material

Available with black, white or red cover colors

- Heavy duty durable construction
- 1/2" Female NPT connection
- Minimum/Maximum Supply Pressure: 25psi/200psi
- Maximum Operating Temperature: 200°F
- Flow rate: 4-7.9 gpm
- Single piece stainless steel or nickel plated bronze body
- Comfortable hand grip
- Easy operation – designed to reduce fatigue
- Replaceable rubber body cover provides temperature insulation and protects spray gun from extensive wear
- All components are user serviceable

Ordering Code	Description
RT12-BB	Bronze body / Black Cover
RT12-BR	Bronze body / Red Cover
RT12-BW	Bronze body / White Cover
RT12-SB	Stainless Steel body / Black Cover
RT12-SR	Stainless Steel body / Red Cover
RT12-SW	Stainless Steel body / White Cover

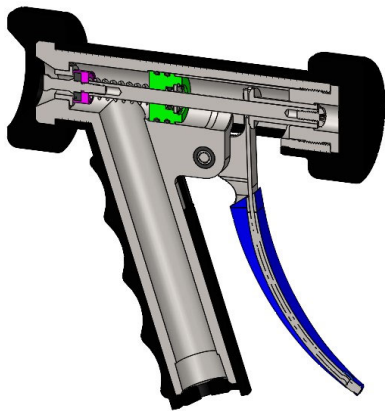

### Rebuild Kit—RT12

Ordering Code	Description
RK-RT12	Internal Cartridge Unit
RT12-20B	Black Rubber Cover
RT12-20R	Red Rubber Cover
RT12-20W	White Rubber Cover





## SPRAY NOZZLES

### Mini Rear Trigger - Model RTB16



Available in Bronze and 304SS material  
 Available with black cover color

- Heavy duty durable construction
- 1/2" Female NPT connection
- Minimum/Maximum Supply Pressure: 25psi/150psi
- Maximum Operating Temperature: 200°F
- Flow rate: 2-5 gpm
- Single piece stainless steel or bronze body
- Stainless steel valve stem and components
- Nitrile o-ring seals and Viton™ valve seat
- Comfortable hand grip
- Easy operation – designed to reduce fatigue
- Replaceable rubber body cover provides temperature insulation and protects spray gun from extensive wear
- All components are user serviceable
- Rebuild kits readily available

Ordering Code	Description
RTB16-BB	Bronze body / Black Cover
RTB16-SB	Stainless Steel body / Black Cover

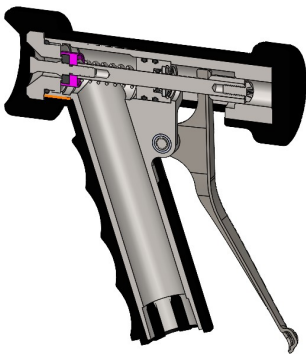

### Rebuild Kit—RTB16

Ordering Code	Description
RK-RTB16	Internal Cartridge Unit
RTB16-17B	Black Rubber Cover



## SPRAY NOZZLES

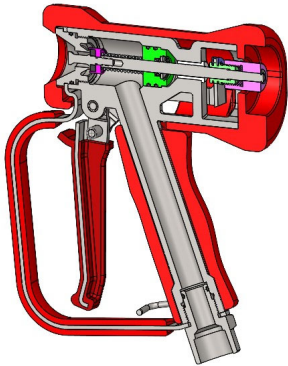

### Front Trigger - Model FT18-SR

Available in 304SS material

Available with red cover color

- Heavy duty durable construction
- 1/2" Female NPT connection
- Minimum/Maximum Supply Pressure: 20psi/200psi
- Maximum Operating Temperature: 200°F
- Flow rate: 4-12 gpm
- Single piece stainless steel body
- Comfortable hand grip
- Easy operation – designed to reduce fatigue
- Replaceable rubber body cover provides temperature insulation and protects spray gun from extensive wear
- All components are user serviceable

Ordering Code	Description
FT18-SR	Stainless Steel body / Red Cover

### Rebuild Kit—FT18

Ordering Code	Description
RK-FT18	Internal Cartridge Unit
FT18-009R	Red Rubber Cover

### Spray Lance - Model AKRHP02-R-L40

Available in 316SS material

Available with red cover color

- Heavy duty durable construction
- 1/2" Female NPT connection
- Teflon® hand grip with air isolation
- Replaceable rubber body for top cover and hand grip
- Controllable water beam from broad to jet spray
- Max temperature 200°F
- Max pressure 350 psi



### Rebuild Kit—AKRHP02-R-L40

Ordering Code	Description
RK-AKRL40	Internal Cartridge Unit
RECOVER-R	Spray Nozzle Cover Top—Red
REGRIPP-RHP-R	Spray Nozzle Dover Hand Grip—Red

## MANUAL REWIND HOSE REELS

Available in both carbon steel and stainless steel materials, our hose reels are built of the highest quality materials to stand up to the most demanding conditions of any industry. We offer a wide selection of hose reels to meet your specifications in size and capacity. The heavy duty design and construction of our reels ensure that they are built to outlast the competition and save you money.



Series 1500 standard configuration shown with crank rewind

### Series 1500

- To handle single 3/8" through 5/8" I.D. hose.
- Lightweight, compact reels designed for long lengths of hose in manual and power rewind configurations.
- Manual rewind reels include: cam-lock drag brake, spring actuated pin lock and direct crank rewind.
- Standard inlet: 90° ball bearing swivel joint, 1/2" female NPT threads.
- Standard outlet: 1/2" female NPT threads.
- Standard pressures to 3000 psi. Available up to 10,000 psi – must specify.
- Temperatures from -40° F to +400° F.
- Available in Carbon Steel and Stainless Steel.
- Hose capacity: Up to 500' of 3/8" and 350' of 5/8".



Series 1800 standard configuration shown with crank rewind

### Series 1800

- To handle single 5/8" or 3/4" I.D. hose.
- Lightweight, compact reels designed for long lengths of hose.
- Manual rewind includes: cam-lock drag brake, spring actuated pin lock and direct crank rewind.
- Standard inlet: 90° stainless steel ball bearing swivel joint, 1" female NPT threads.
- Standard outlet: 3/4" female NPT threads.
- Rollers and roller mounting brackets are accessory items.
- Pressures to 1000 psi.
- Temperatures from -65° F to +250° F.
- Available in Carbon Steel and Stainless Steel.
- Hose capacity: Up to 300' of 5/8" and 200' of 3/4".



## SPRING REWIND HOSE REELS



Series 700 standard SR configuration shown

### Series 700

- To handle 1/4" through 1/2" I.D. hose.
- Rollformed channel frame for heavy-duty applications.
- Non-sparking ratchet assembly.
- Declutching arbor to prevent damage from reverse winding.
- Standard inlet: 90° balanced pressure swivel joint, 1/2" female NPT threads.
- Standard outlet: 1/2" female NPT threads.
- Standard pressures to 3000 psi. Available up to 10,000 psi—must specify.
- Temperatures from -40° F to +400° F.
- Available in Carbon Steel and Stainless Steel.
- Hose capacity: Up to 100' of 1/4" and 125' of 1/2".



Series 800 standard SR configuration shown

### Series 800

- To handle 3/4" or 1" I.D. hose.
- Roll-formed channel frame for heavy-duty applications.
- Non-sparking ratchet assembly.
- Declutching arbor to prevent damage from reverse winding.
- Standard inlet: 90° stainless steel ball bearing swivel joint, 1" female NPT threads.
- Standard outlet: 1" female NPT threads.
- Pressures to 1000 psi.
- Standard temperatures from -65° F to +250° F.
- 4-way roller assembly.
- Available in Carbon Steel and Stainless Steel.
- Hose capacity: Up to 100' of 3/4" and 100' of 1".





## SPRING REWIND HOSE REELS

### Specifying Spring Rewind Reels

#### Important Installation Guide

For proper reel operation, rewind springs must be precisely matched to the job. Your order should include a detailed description of how the reel will be installed and used. This will also help to determine the best roller position.

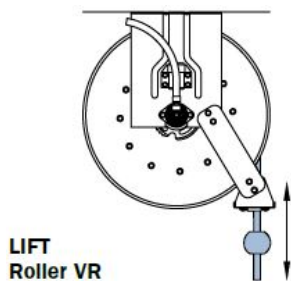

#### Vertical Lift

Reel is installed overhead, on wall or ceiling, to lift hose/cable and product being handled. Spring must have power to lift total weight of hose/cable plus any weight which will be attached to the hose/cable such as a power tool. Reel can be manually operated or pay out and rewind automatically.

Specify roller position **VR** when:

- Reel will be installed in the upright position and hose/cable will be pulled upright from the reel.
- Reel will be installed on ceiling to lift hose/cable.
- Reel will be installed on a wall with hose/cable to be pulled straight out.

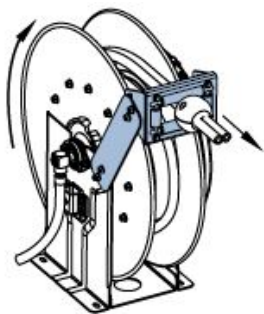

Specify roller position **TR** when:

- Reel will be installed on floor.
- Reel will be installed on ceiling with hose/cable to pay out parallel to the ceiling.
- Inlet supply line will come in from the left.

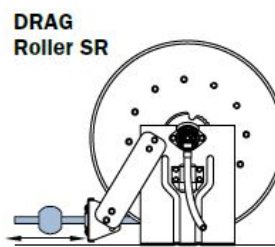

#### Drag

Reel is stationary and retracts hose/cable across floor or other surface. Spring must have power to compensate for friction. Reel can be manually

Specify roller position **SR** when:

- Reel will be installed in the upright position at any point from floor to eye level.
- Reel will be installed on a wall with hose/cable to be retracted close to the wall.
- Reel will be installed on ceiling and hose/cable will pay out parallel to and close to the ceiling.
- Inlet supply line will come in from the right.

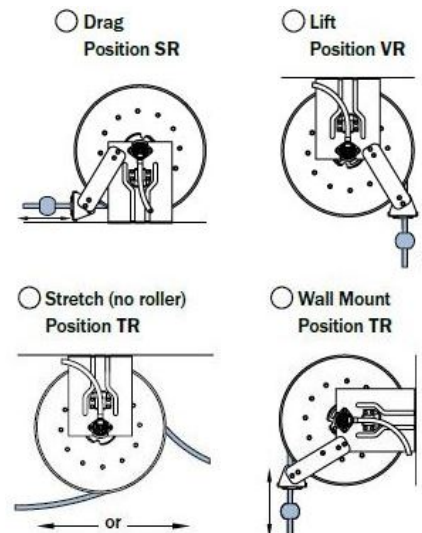



## SWIVEL ADAPTERS

ARCHON swivel adapters are economical and quality made. The hose barb length is sufficient for both clamp or band attachment, or mechanical crimping.

The 360° swivels are available for hose/nozzle connections and also for hose/unit connections.

Optional combinations are available upon request.



Model	Description	Material
SW625BS	1/2" MNPT swivel x 5/8" ID hose barb	Brass / Stainless Steel
SW750BS	1/2" MNPT swivel x 3/4" ID hose barb	Brass / Stainless Steel
SW625SS	1/2" MNPT swivel x 5/8" ID hose barb	Stainless Steel / Stainless Steel
SW750SS	1/2" MNPT swivel x 3/4" ID hose barb	Stainless Steel / Stainless Steel
SWUE625BS	3/4" MNPT swivel x 5/8" ID hose barb	Brass / Stainless Steel
SWUE750BS	3/4" MNPT swivel x 3/4" ID hose barb	Brass / Stainless Steel
SWUE625SS	3/4" MNPT swivel x 5/8" ID hose barb	Stainless Steel / Stainless Steel
SWUE750SS	3/4" MNPT swivel x 3/4" ID hose barb	Stainless Steel / Stainless Steel

ARCHON model SWB swivel adapters allow full vertical, horizontal and circular spray gun movement. Available on all ARCHON hose and spray gun configurations.

The 360° ball swivel prevents hose kinking and is operator friendly. The operator will experience resistance-free mobility eliminating any stress concerns.



Model	Description	Material
SWB625SS	1/2" MNPT swivel x 5/8" ID hose barb	Stainless Steel / Stainless Steel
SWB750SS	1/2" MNPT swivel x 3/4" ID hose barb	Stainless Steel / Stainless Steel



## TERMS AND CONDITIONS AGREEMENT

**GENERAL:** The following terms and conditions shall constitute the entire Agreement by the Seller for the purchase and sale of ARCHON Industries, Inc. products. Any terms and conditions contained in the Purchaser's purchase order that are different from, in addition to, or vary from ARCHON Industries, Inc. terms & conditions shall not be binding, and are hereby excluded.

**AGREEMENT:** Orders are subject to acceptance in writing by ARCHON Industries, Inc hereinafter referred to as the "Seller" at its Suffern, New York office.

**WARRANTY:** The Seller warrants its products against defects in materials and workmanship for one year from date of shipment. The Seller's warranty will be limited to (at Seller's option) refund of the Seller's selling price, or repair or replacement of the product of part proven to be materially defective when used for the purpose for which it was intended. The Seller shall be liable for no other warranties, oral, written, express or implied. The Seller's warranty obligations and remedies hereunder are solely and exclusively as stated herein. In no event shall the Seller be liable either to customers for incidental or consequential damages or for personal injury or property damages resulting from the use of the products sold. The undertaking of repairs or replacement by Purchaser or its agents without the Seller's written consent shall relieve the Seller of all responsibility herewith.

**FORCE MAJEURE:** The Seller shall endeavor to ship products specified in any acceptance order, but the Seller shall not be considered in default of its obligations hereunder if such performance is presented or delayed because of unavailability of materials, equipment, labor or technical personnel, war, labor strikes, riots, hostilities, fires, accidents, shutdowns of its manufacturing plants or plants supplying it, embargos or inability to secure transportation or because any law, order, proclamation, regulation or ordinance, of any government or because of acts of God or for any other cause beyond the reasonable control of the Seller.

**DELIVERY:** Unless otherwise specified in writing, delivery will be FOB, Suffern.

**PRICES & DESIGNS:** Prices and designs are subject to change without notice.

**LIMITATION OF LIABILITY:** No claims made by the Purchaser whether as to goods delivered or for non-delivery of goods shall be greater than the purchase price of the goods. Under no circumstances shall the Seller be liable for consequential damages.

**TAXES:** All application federal, state or local sales, use or excise taxes are

the responsibility of the Purchaser, and are in addition to prices printed or stated. The Seller shall have the right to invoice separately any such tax as may be imposed at a later date. Applicable tax exemption certificates must accompany any order to which same applies.

**RETURN OF GOODS:** The Seller will not accept return or any product unless a returned goods authorization number has first been obtained from the Seller in which case, credit will be issued after inspection and fulfillment of the following criteria:

- 1 - All goods must be returned prepaid freight and in original condition. If not, credit will not be issued and goods will be returned to Purchaser at Purchaser's expense.
- 2 - A stocking and handling charge of 20% will be imposed on all returned goods.
- 3 - Transportation charges on all returned goods are to be paid by Purchaser in all cases.

**CANCELLATION:** A purchase order or any part thereof which is accepted by the Seller may not be cancelled unless, and until the Seller has deemed what action is necessary and advisable to minimize costs resulting from cancellation.

Orders for non-customized goods that have already been shipped are subject to a 20% handling and restocking charge.

**TERMS OF PAYMENT:** U.S. terms of payment are net 30 upon credit approval. The Seller reserves the right to defer shipment until receipt of cash, if, in the Seller's judgment, the Purchaser's financial condition becomes unsatisfactory. A service charge of 1.5% per month will be charged on all accounts that exceed 60 days from the date of invoice. The Seller reserves the right to alter the payment terms.

**PARTIAL INVALIDITY:** If any provision of the Agreement is or becomes unenforceable or invalid at any time under law, rule or regulation, no other provisions of this Agreement shall be affected thereby and remaining provisions of this Agreement shall continue in force as if such enforceable or invalid provision did exist.

**GOVERNING LAW:** This Agreement shall be governed in all respects by the laws of New York.

**ARBITRATION:** All disputes between the Purchaser and Seller in relation with this Agreement shall be settled through negotiation. In the event where no settlement can be reached through negotiation, the dispute shall be submitted for Arbitration. The Arbitration shall take place in New York, NY, USA. The decision of the Arbitration shall be accepted as final and binding upon both parties.

**Check out some of our other products  
for the Processing Industry...**

- Manways
- Sightglasses
- Lighting
- Liquid Level Gauges
- Gauge Cocks
- Sight Flow Indicators
- Sprayballs
- DIN Fittings

**Corporate Headquarters - USA**

ARCHON Industries, Inc.

357 Spook Rock Road, Suffern, NY 10901

Toll Free: 800-554-1394

Tel: 845-368-3600

[orders@ARCHONind.com](mailto:orders@ARCHONind.com)