



STAINLESS TOOL CART—MODEL 1201

Description:

ARCHON STAINLESS TOOL CART model 1201, offers the perfect way to transport tools and service equipment anywhere within your production facility. Constructed from polished 304 SS, it is washdown ready for the harshest production environments in the food and beverage, chemical and pharmaceutical industries. All bins and trays are smooth and perforated to allow for drainage.

5" swivel and locking casters provide smooth rolling and easy movement over all types of flooring, and the locks provide stability when not in motion.

The included (60) straight posts, (9) hook posts and (2) hanging bins may be positioned in any of the (152) mounting holes. Top, middle and lower trays are provided for transporting heavy and bulky items, and the push / pull bar allows for a comfortable grip while moving.



Features and Specifications:

- 40-1/4"L x 30"W x 47-1/2"H
- Sized to fit through standard doorways
- Polished 304 SS construction
- 210 lb. approximate weight
- 5" swivel casters (2) locking
- (60) Removable straight posts
- (9) Removable hooked posts
- (2) Removable hanging bins
- (3) Trays for tools and bulky items
- Holes in all bins trays for drainage

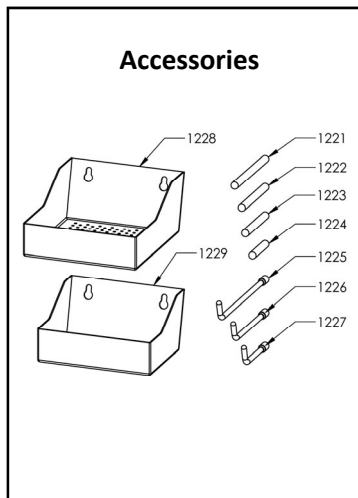
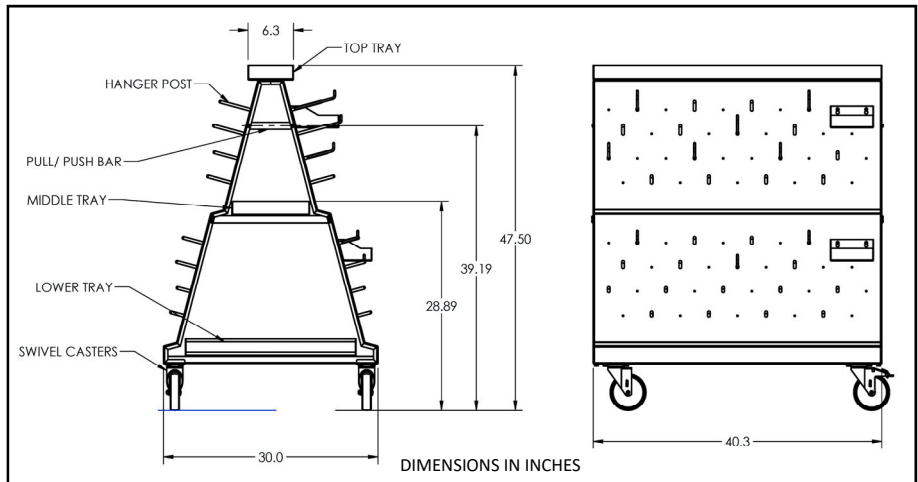

Item Number	Description
1201	Standard Cart Assembly with standard posts and bins.
Optional Accessories	1221 Straight Post — 4" with screw
	1222 Straight Post — 3.5" with screw
	1223 Straight Post — 3" with screw
	1224 Straight Post — 2" with screw
	1225 Hook Post — 6.5" with screw
	1226 Hook Post — 4.5" with screw
	1227 Hook Post — 3" with screw
	1228 Hanging Bin — 6" depth with hardware
	1229 Hanging Bin — 4" depth with hardware