

# ARMORED LIQUID LEVEL GAUGES

## Reflex Model RM and Transparent Model TM

ARCHON models RM and TM are medium pressure gauges and are available in both single and multiple section types 1 through 9 with a one-piece liquid chamber. They are machined from solid bar stock of cold rolled carbon steel, stress relieved and assembled complete with drop forged steel covers, tempered borosilicate glass, gaskets, bolts and nuts, making the gauges resistant to thermal shock, heat, corrosion and abrasion.

The liquid chamber is recessed to hold each individual gauge glass and gasket snugly, eliminating any possible movement by internal pressure.

All bolts are properly spaced to ensure uniform pressure on the glass and gaskets, and are manufactured from ASTM grade steel. The gaskets used are of the finest quality, uniform in thickness and accurately die-cut. Our standard gasket material is compressed non-asbestos, but can be interchanged with alternate material depending on the liquid being used.

Gauges are also available in Stainless Steel, Monel, or other alloys.

Please review the tables below for temperature and pressure ratings..



sales@ARCHONind.com

Pressure and Temperature Ratings: ARCHON Reflex Gauges Model RM						
Size Gauge	100°F	200°F	300°F	400°F	500°F	600°F
1 x 1	3000	2800	2625	2475	2250	2000
1 x 2	2850	2700	2500	2360	2150	1900
1 x 3	2700	2600	2400	2200	2000	1800
1 x 4	2600	2450	2350	2150	1900	1750
1 x 5	2550	2400	2200	2000	1850	1600
1 x 6	2400	2250	2100	1900	1700	1500
1 x 7	2250	2100	1975	1825	1650	1450
1 x 8	2100	2000	1850	1700	1550	1350
1 x 9	2000	1900	1775	1625	1470	1300

All Gauges Hydrostatic Tested: 1.5 times 100°F Rating

Pressure and Temperature Ratings: ARCHON Transparent Gauges Model TM						
Size Gauge	100°F	200°F	300°F	400°F	500°F	600°F
1 x 1	2000	1850	1750	1650	1500	1300
1 x 2	1900	1750	1650	1500	1450	1250
1 x 3	1800	1650	1500	1400	1300	1100
1 x 4	1700	1550	1400	1300	1200	1070
1 x 5	1600	1450	1300	1200	1100	1000
1 x 6	1500	1300	1200	1100	1000	900
1 x 7	1400	1200	1100	1000	925	850
1 x 8	1300	1100	1000	900	850	750
1 x 9	1200	1050	900	800	750	650

All Gauges Hydrostatic Tested: 1.5 times 100°F Rating

Correction Factor Table-To be Applied to the 100% Ratings Listed Above

% of Rating	100%	75%	50%	25%
Chamber	Carbon Steel, 304SS and 316SS	Monel		
Gasket Material Liquid Side	Teflon Lo-Flo, Non-Asbestos		Pure Teflon, Kel-F Shields	
Gasket Material Liquid & Cover Side	Non-Asbestos		Teflon Lo-Flo	Pure Teflon
Optional Features	Non-Frost Extensions (Max. Temp. 100°F)			

# ARMORED LIQUID LEVEL GAUGES

**REFLEX GAUGES** - This gauge type is equipped with flat reflex glass comprised of reflecting prisms which cause the liquid inside to appear black in color. The space above appears silvery in direct contrast assuring a distinct reading of the liquid level.

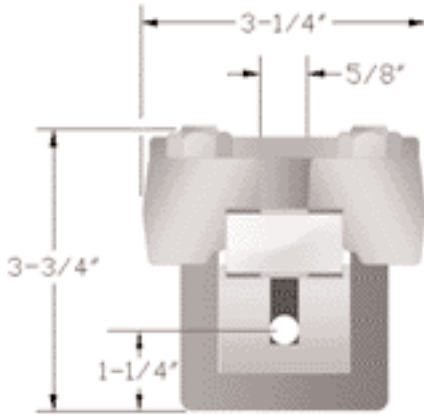

Model RL/RM Reflex

**TRANSPARENT GAUGES** - This gauge type is equipped with two flat plain glass sections; one on either side of the liquid chamber. This allows light to pass through the gauge permitting clear observation of liquid level, color and clarity. Plastic or MICA shields can be furnished when handling caustic substances, acids or media corrosive to glass.

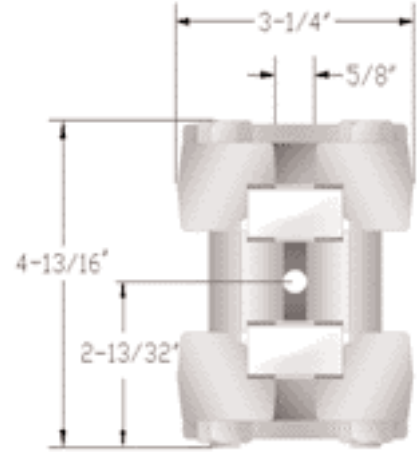

Model TL/TM Transparent

**Connection styles available:**  
1/2" or 3/4" NPT Female with end, side or back connections.

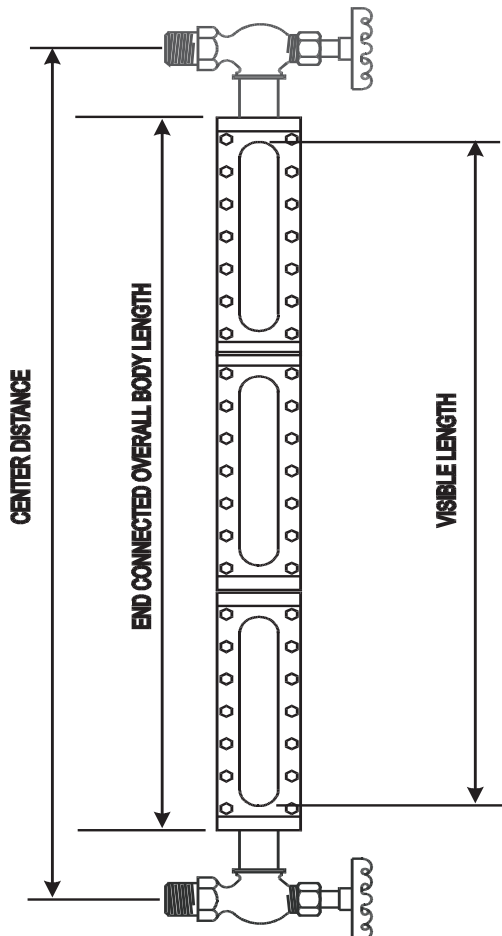

Sections	Glass Size	Visible Length		End Connected Overall Length	
		inch	mm	inch	mm
1	1	3.750	95	5.250	133
1	2	4.750	121	6.250	159
1	3	5.750	146	7.250	184
1	4	6.750	171	8.250	210
1	5	7.875	200	9.375	238
1	6	9.125	232	10.625	270
1	7	10.250	260	11.750	298
1	8	11.875	302	13.375	340
1	9	12.625	321	14.125	359
2	4	15.000	381	16.500	419
2	5	17.250	438	18.750	476
2	6	19.750	502	21.250	540
2	7	22.000	559	23.500	597
2	8	25.250	641	26.750	679
2	9	26.750	679	28.250	718
3	6	30.375	772	31.875	810
3	7	33.750	857	35.250	895
3	8	38.625	981	40.125	1019
3	9	40.875	1038	42.375	1076
4	7	45.500	1156	47.000	1194
4	8	52.000	1321	53.500	1359
4	9	55.000	1397	56.500	1435
5	7	57.250	1454	58.750	1492
5	8	65.375	1661	66.875	1699
5	9	69.125	1756	70.625	1794
6	8	78.750	2000	80.250	2038
6	9	83.250	2115	84.750	2153
7	8	92.125	2340	93.625	2378
7	9	97.375	2473	98.875	2511
8	8	105.500	2680	107.000	2718
8	9	111.500	2832	113.000	2870
9	8	118.875	3019	120.375	3058
9	9	125.625	3191	127.125	3229
10	8	132.250	3359	133.750	3397
10	9	139.750	3550	141.250	3588

sales@ARCHONind.com