

ARMORED LIQUID LEVEL GAUGES

ARCHON model RLG and TLG Weld Pad Type Gauges

ARCHON Weld Pad Gauges are designed to be welded directly to a tank or other liquid-containing vessels. The body lengths and visibility are the same as standard gauges in single or multiple section type. These gauges consist of a pad which is machined from bar stock 3 1/2" wide, standard forged covers, glass, gaskets & bolts.

The model RLG with Reflex Glass is used where only the reading of the liquid level is desired.

The model TLG with Transparent Glass is used where the installation is made on each side of the vessel for look through visibility.

The Weld Pad is normally furnished flat but can be machined to fit the contour of the vessel.

The Pad material can be Carbon Steel, Stainless Steel or other specified Alloys.

The standard cover is Forged Steel but other Alloys are available.

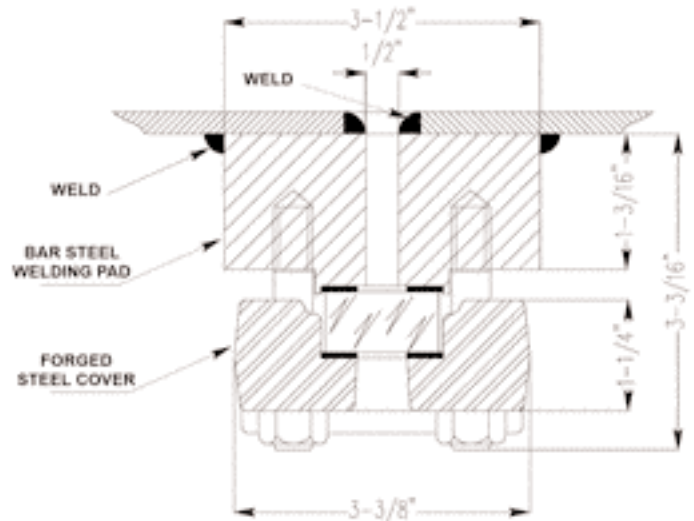

RLG / TLG Model	Sections	Glass Size	Visible Length, V		Overall Length, L	
			inch	mm	inch	mm
1 x 1	1	1	3 3/4	95	5 1/4	133
1 x 2	1	2	4 3/4	121	6 1/4	159
1 x 3	1	3	5 3/4	146	7 1/4	184
1 x 4	1	4	6 3/4	171	8 1/4	210
1 x 5	1	5	7 7/8	200	9 3/8	238
1 x 6	1	6	9 1/8	232	10 5/8	270
1 x 7	1	7	10 1/4	260	11 3/4	298
1 x 8	1	8	11 7/8	302	13 3/8	340
1 x 9	1	9	12 5/8	321	14 1/8	359
2 x 4	2	4	15	381	16 1/2	419
2 x 5	2	5	17 1/4	438	18 3/4	476
2 x 6	2	6	19 3/4	502	21 1/4	540
2 x 7	2	7	22	559	23 1/2	597
2 x 8	2	8	25 1/4	641	26 3/4	679
2 x 9	2	9	26 3/4	679	28 1/4	718
3 x 6	3	6	30 3/8	772	31 7/8	810
3 x 7	3	7	33 3/4	857	35 1/4	895
3 x 8	3	8	38 5/8	981	40 1/8	1019
3 x 9	3	9	40 7/8	1038	42 3/8	1076
4 x 7	4	7	45 1/2	1156	47	1194
4 x 8	4	8	52	1321	53 1/2	1359
4 x 9	4	9	55	1397	56 1/2	1435
5 x 7	5	7	57 1/4	1454	58 3/4	1492
5 x 8	5	8	65 3/8	1661	66 7/8	1699
5 x 9	5	9	69 1/8	1756	70 5/8	1794

sales@ARCHONind.com