

NOTES:

1. FASTENERS CONFORM TO THE REQUIREMENTS OF ASME B&PV CODE, SECTION VIII
2. FLANGE MATERIAL CONFORMS TO THE REQUIREMENTS OF ASME B&PV CODE, SECTION VIII
3. PRESSURE RATING: 150 PSI/FV @500 °F. TEMPERATURE RATING MAY BE LIMITED BY GASKET SELECTION.

REVISIONS				
REV	DESCRIPTION	DATE	DRAWN	APPROVED
A	INITIAL RELEASE	06/15/17	J.CUSTY	

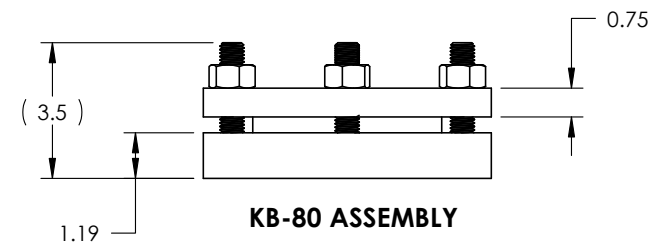
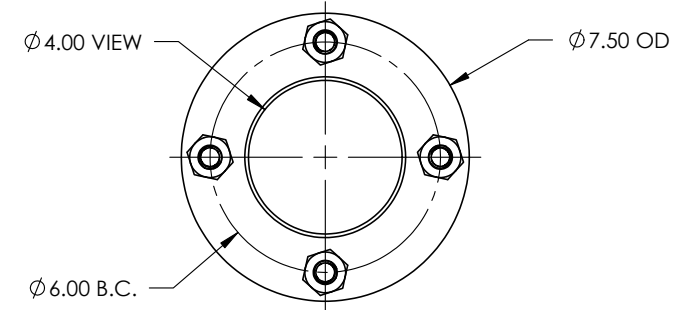
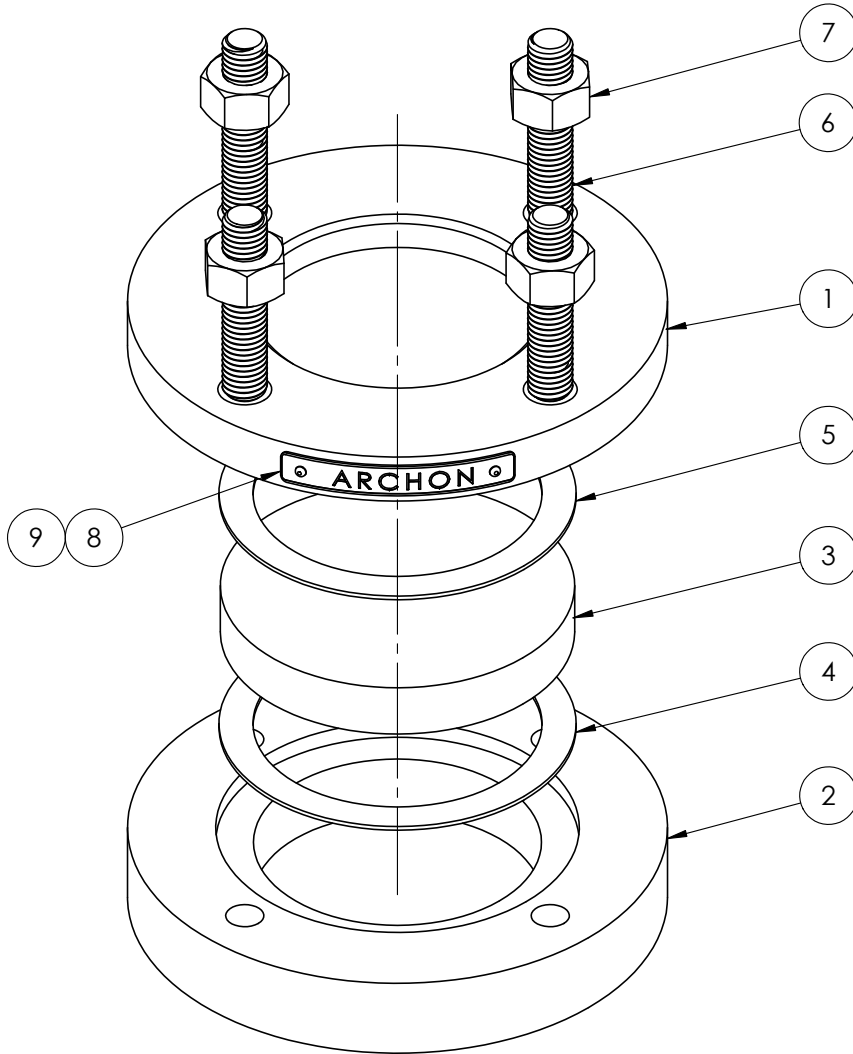

ITEM	DESCRIPTION	QTY
9	DRIVE SCREW	2
8	LABEL, ARCHON	1
7	HEX NUT, HEAVY, 5/8-11 UNC	4
6	STUD, 5/8-11 UNC X 3" LG	4
5	CUSHION GASKET	1
4	SEAL GASKET	1
3	LENS	1
2	WELD PAD	1
1	COVER FLANGE	1

BILL OF MATERIAL

UNLESS OTHERWISE SPECIFIED	DR	JPC	DATE 06/13/17
DIMENSIONS IN INCHES	CHKD		DATE
DECIMALS FRACTIONS	APVD		DATE
X ± .030 ± 1/64	APVD		DATE
XX ± .015 ANGLES ±.5			
XXX ± .010			
REMOVE ALL BURRS AND BREAK SHARP EDGES .02 MAX	MATERIAL: PER ORDER		
SURFACE ROUGHNESS ✓	FINISH:		
DIMENSIONS AFTER PLATING OR COATING			
THIRD ANGLE PROJECTION	DO NOT SCALE DRAWING		

ARCHON INDUSTRIES, INC.
 357 SPOOK ROCK ROAD
 SUFFERN, NY 10901
 (845) 368-3600
 FAX (845) 368-3040

TITLE: ASSEMBLY, KB-80		
SIZE A	SCALE:	SHEET 1 OF 1
DWG. NO. KB-80-ASM		REV A