

2

1

**NOTES:**

1. FASTENERS CONFORM TO THE REQUIREMENTS OF ASME B&PV CODE, SECTION VIII
2. FLANGE MATERIAL CONFORMS TO THE REQUIREMENTS OF ASME B&PV CODE, SECTION VIII
3. PRESSURE RATING: 150 PSI/FV @500 °F. TEMPERATURE RATING MAY BE LIMITED BY GASKET SELECTION.

REVISIONS				
REV	DESCRIPTION	DATE	DRAWN	APPROVED
A	INITIAL RELEASE	06/15/17	J.CUSTY	

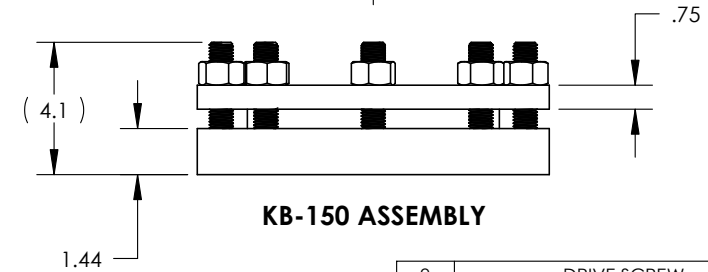
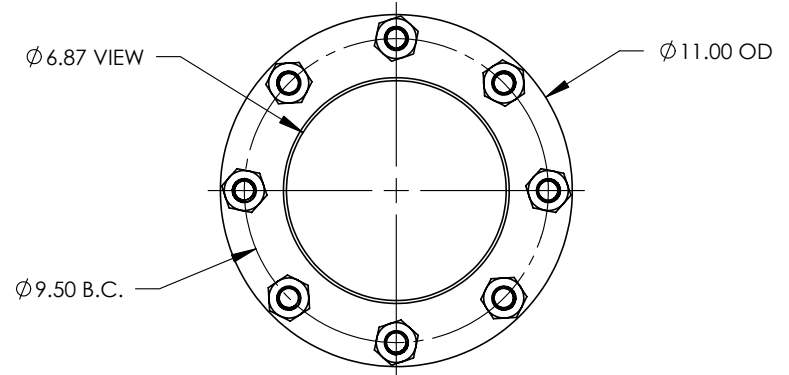
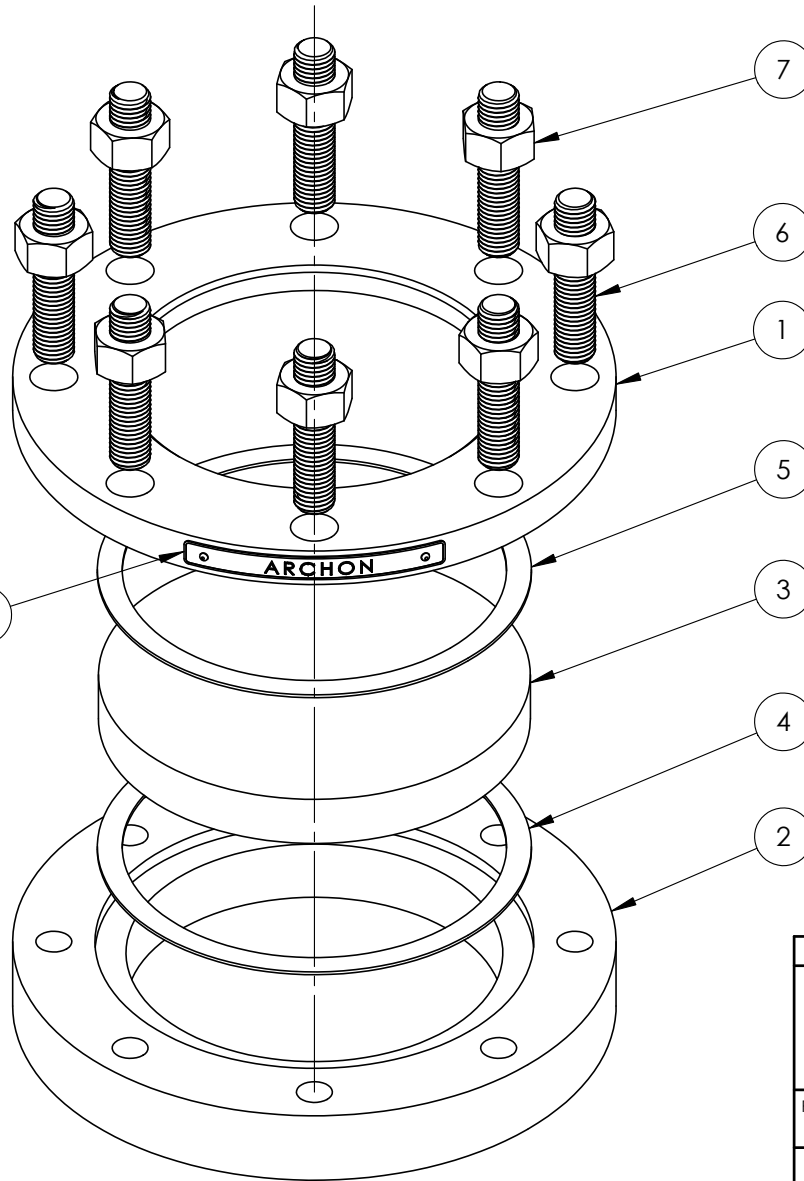

9	DRIVE SCREW	2
8	LABEL, ARCHON	1
7	HEX NUT, HEAVY, 3/4-10 UNC	8
6	STUD, 3/4-10 UNC X 3.5" LG	8
5	CUSHION GASKET	1
4	SEAL GASKET	1
3	LENS	1
2	WELD PAD	1
1	COVER FLANGE	1
ITEM	DESCRIPTION	QTY.

**BILL OF MATERIAL**

UNLESS OTHERWISE SPECIFIED	DR	JPC	DATE	06/13/17
DIMENSIONS IN INCHES	CHKD		DATE	
DECIMALS	APVD		DATE	
FRACTIONS	APVD		DATE	
X ± .030				
± 1/64				
XX ± .015				
ANGLES				
XXX ± .010				
±.5				
REMOVE ALL BURRS AND BREAK SHARP EDGES .02 MAX	MATERIAL: PER ORDER			
SURFACE ROUGHNESS ✓	FINISH:			
DIMENSIONS AFTER PLATING OR COATING				
THIRD ANGLE PROJECTION	DO NOT SCALE DRAWING			



357 SPOOK ROCK ROAD  
SUFFERN, NY 10901  
(845) 368-3600  
FAX (845) 368-3040

TITLE:

ASSEMBLY, KB-150

SIZE

SCALE:

SHEET 1 OF 1

**A**

DWG. NO.

KB-150-ASM

REV

**A**

2

1