



ARCHON Industries, Inc.

Circular Sight Windows

Model: SS



Installation / Operation / Maintenance Instruction

Instruction No.:

1032

Issued:

09/23/2011

Approved:

F. Bongiorno, Engineering Mgr

357 Spook Rock Road
Bldg # 1 – 505
Suffern, NY 10901



Tel.: (845) 368-3600
Fax: (845) 368-3040
sales@archonind.com

TABLE OF CONTENTS

PAGE

Product Warranty	1
1.0 About the Manual	1
2.0 Introduction	1
2.1 System Description	2
3.0 Available Models & Sizes.....	2
3.1 Pressure and Temperature Specifications.....	2
4.0 Installation	2
4.1 Inspection.....	3
4.2 Location precautions.....	3
4.3 Assembling / Re-assembling	3
5.0 Operation	3
6.0 Maintenance	4
6.1 Maintenance Procedures	4
6.2 Troubleshooting	4
7.0 Removal / Disassembly / Re-assembly	5
7.1 Disassembly	5
7.2 Re-assembly	5
8.0 Telephone Assistance	5
9.0 Sectional view of Sight glass.....	6

TABLES AND FIGURES

Figure 1 Sectional view of Sight glass	6
---	---

PRODUCT WARRANTY

Archon Industries Inc., warrants its products as designed and manufactured by Archon to be free of defects in material and workmanship for a period of one year after the date of installation or eighteen months after the date of manufacture, whichever is earliest. Archon will, at its option, replace or repair any products that fail during the warranty period due to defective material or workmanship.

Prior to submitting any claim for warranty service, the owner must submit proof of purchase to Archon and obtain written authorization to return the product. Thereafter, the product shall be returned to Archon in Suffern, New York, with freight prepaid.

This warranty shall not apply if the product has been disassembled, tampered with, repaired or altered outside of the Archon factory, or if it has been subjected to misuse, neglect or accident.

Archon's responsibility hereunder is limited to repairing or replacing the product at its expense. Archon shall not be liable for loss, damage, or expenses directly or indirectly related to the installation or use of its products, or from any other cause or for consequential damages. It is expressly understood that Archon is not responsible for damage or injury caused to other products, building, property or persons, by reason of the installation or use of its products.

THIS IS ARCHON'S SOLE WARRANTY AND IN LIEU OF ALL OTHER WARRANTIES, EXPRESSED OR IMPLIED WHICH ARE HEREBY EXCLUDED, INCLUDING IN PARTICULAR ALL WARRANTIES OF MERCHANTABILITY OR FITNESS, FOR A PARTICULAR PURPOSE.

This document and the warranty contained herein may not be modified and no other warranty, expressed or implied, shall be made by or on behalf of Archon unless modified or made in writing and signed by the President or a Vice President of Archon.

1.0 About the Manual

This manual has been prepared as an aid and guide for personnel involved in installation and maintenance. All instructions must be read and understood thoroughly before attempting any installation, operation or maintenance.



Failure to follow instructions could result in breakage of the sight window glass, resulting in fluid escaping from the vessel and fragmenting glass. Always wear safety glasses when installing, servicing or operating a sight window. Failure to follow precautions can result in personal injury and property damage.

2.0 Introduction

Archon Industries, Inc.'s circular sight windows are designed for observation of fluid flow in process lines or for observation of the level of the contents in a vessel or tank.

A circular sight window permits the convenient monitoring of:

- ✓ Fluid presence - change in level or volume of liquid in the viewing area
- ✓ Fluid color - change in tint or hue
- ✓ Fluid clarity - change in opacity, brightness or purity

The window assists the observer by creating a monitoring port for process fluid volumes, directions, and reactions without exposing the fluid to the external environment.

2.1 System Description

The Archon Circular sight window consists of five basic components. Each component may vary slightly, depending on the desired physical and mechanical properties for the indicator. Refer to the sectional view in Section 9.

Weld ferrule - the weld ferrule provides a mounting periphery on the vessel. The weld ferrule provides a machined surface with which the gasket makes a seal and the external threads hold the grooved collar nut.

Grooved Collar nut - this provides a machined surface in which the glass and cushion are protectively seated. The grooved collar nut provides an effective means of compressing the gasket & cushion when fitted over the weld ferrule to seal all the gaps.

Glass Plate - the glass provides a window for fluid observation.

Gaskets - when the collar nut is tightened, the gasket is compressed to tightly seal the gap and prevent leakage.

Cushions – the cushions are compressed when the collar nut is tightened. This seals the gap and prevents leakage.

3.0 Available Models & Sizes

Archon offers the standard Circular sight window model SS in the following sizes: DN65, DN80, DN100 & DN125.

Standard material of construction for the grooved collar nut is 304SS. Weld ferrule is available in 304L, 316L or other commercially available alloys. Material certificate for weld ferrules can be provided for code vessels.

Standard glass is tempered borosilicate with PTFE cushion. The gasket on product side is Silicone, with other options available.

Special materials and special configurations are available.

3.1 Pressure and Temperature Specifications

Maximum Pressure:	85 psig
Vacuum Level:	Full vacuum
Maximum Temperature:	500° F

4.0 Installation

Upon receipt of the Archon Circular sight window, check all components carefully for damage which may have been incurred during shipping. **IMPORTANT: If damage is evident or suspected, do not attempt installation. Notify your carrier immediately and request a damage inspection.**

Archon's standard Circular sight window unit is comprised of (1) weld ferrule, (1) grooved collar nut, (1) cushion, (1) glass and (1) gasket.

Confirm that the information provided conforms to the size, model, and performance data on the purchase order and the actual operating conditions at the installation site.

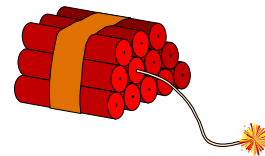

DANGER

Exceeding the design ratings or application's data limits can cause the glass to break, the unit to leak or sudden release of pressure. Do not exceed the design ratings for each particular unit. Failure to keep operating conditions below design ratings may result in severe personal injury and property damage.

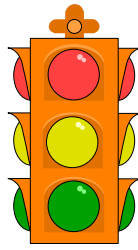

CAUTION

Only qualified, experienced personnel who are familiar with sight window equipment and thoroughly understand the implications of the tables and all the instructions should install the Circular sight glass. Failure to read and comply with the following instructions could result in personal injury or property damage.

4.1 Inspection

- i. Examine the glass to see that it is free of scratches, chips or other imperfections.
- ii. Ensure that the grooved collar nut and weld ferrule have been cleaned and are free of any foreign material.

4.2 Location Precautions

Locate the Circular sight glass:

- i. where it can be easily seen;
- ii. away from areas where objects may be dropped, thrown or generally allowed to contact the glass;
- iii. protected from dust, grit or other objects that could damage the glass;
- iv. protected from external thermal shock, such as a high temperature application being exposed to a cold air blast or cold water wash.

4.3 Assembling / Re-assembling

Refer to the sectional view in Section 9 for component identification assistance and position.

- i. Carefully remove the glass plate from the shipping package and place in a safe area.
- ii. Clean any material from gasket seating cavity.
- iii. Place the cushion in the collar nut.

- iv. Place a rubber band around the circumference of the glass to properly center the glass.
- v. Place and align the gasket in the seating cavity of the weld ferrule.
- vi. Carefully place glass plate on the gasket until it rests level on the gasket.
- vii. Carefully align the collar nut with the weld ferrule and tighten the collar nut over the weld ferrule.

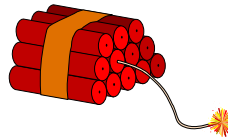

DANGER

Tightening under pressure increases the likelihood of the glass plate breaking and the contents spraying out of the vessel. The sight window must be relieved of all pressure or vacuum, and allowed to reach ambient temperature. The vessel must be drained or purged of all fluids before re-torque-ing. Failure to follow this procedure could result in severe personal injury and property damage.

5.0 Operation

Before initializing sight window operation, check that all installation procedures have been completed. Use only qualified experienced personnel who are familiar with sight window equipment and thoroughly understand the implications of the tables and all the instructions. Check that the clamped connection is pressure tight. Check that glass is clean and free of any damage.

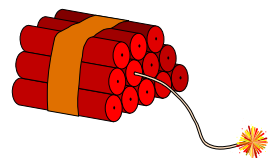

DANGER

Sight windows should be brought into service slowly to avoid excessive shock or stress on the glass. Rapid pressurization of a sight window can cause glass breakage/fragmentation and fluid leakage. Failure to take proper precautions could result in severe personal or property damage.

6.0 Maintenance

Use only qualified experienced personnel who are familiar with sight window equipment and thoroughly understand the implications of the tables and all the instructions.

Create a maintenance schedule for each specific installation of a Sight Window. On all inspections, regularly check the following items:

- 1) glass for cleanliness and signs of damage or wear,
- 2) sight window for signs of leakage at gaskets or threaded connections,
- 3) sight window for signs of internal or external corrosion.

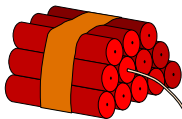

DANGER

DO NOT proceed with any maintenance while the sight window is in operation. Pressure increases the likelihood of the glass plate breaking and contents spraying out of the vessel. A sight window in service must be relieved of all pressure or vacuum, allowed to reach ambient temperature and the vessel drained or purged of all fluids before conducting maintenance. Failure to follow this procedure could result in severe personal injury and property damage.

6.1 Maintenance Procedures

GLASS should be given regular and careful attention. Keep the glass clean, using a commercial glass cleaner and a soft cloth. Inspect the surface of the glass for any clouding, etching or scratching or physical damage such as bruises checks or corrosion. Glass that is damaged is weakened and may break under pressure. Shining a light at approximately a 45° angle will aid in detecting some of these conditions. Typical damaged areas will glisten more brightly than the surrounding glass because the light is reflected.

Detection of any damage, problem areas or surface wear is sufficient evidence to take the sight window out of service. **DO NOT** proceed with operations until the glass has been replaced with a glass replacement kit following the assembly instructions in Section 4.

GASKET LEAKS must be repaired immediately. **DO NOT** proceed with operations until gaskets have been replaced by following the assembly instructions in Section 4.

CONNECTION LEAKS at any threaded connection should be corrected by re-tightening the collar nut.

CORROSION may occur if the user has selected an improper material for the Circular Sight Window application. It is the responsibility of the user to choose a material of construction compatible with both the contained fluid and the surrounding environment. If internal or external corrosion is present, the user must immediately perform an investigation. It may be necessary to contact an authorized Archon distributor to better determine the origin of the corrosion.

6.2 Troubleshooting

Problem: glass or shield becomes etched or clouded in service

Cause: fluid being handled is not compatible with the glass

Solution: replace the glass

Problem: glass continually breaks in service

Cause: warped body as a result of mechanical or thermal stresses

Solution: reduce the stress and replace sight window

Problem: leakage from threaded connection

Cause: faulty gasket or insufficient tightening of collar nut

Solution: re-tighten the collar nut. If it doesn't resolve the leakage, remove the collar nut, replace the gasket / change the gasket material and re-tighten the clamp.

7.0 Removal/Disassembly/Reassemble

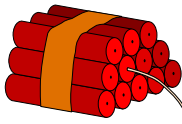

DANGER

DO NOT proceed with any removal or disassembly while the sight window is in operation. Pressure increases the likelihood of the glass plate breaking and contents spraying out of the vessel. A sight window in service must be freed of all pressure or vacuum, allowed to reach ambient temperature and the vessel drained or purged of all fluids before proceeding. Failure to follow this procedure could result in severe personal injury and property damage.

7.1 Disassembly

The Circular sight glass should be disassembled by holding the sight window firmly and loosening the collar nut. Remove the collar nut, then the glass and the gasket. Once a sight window has been disassembled, all glass must be disposed of because of wear; and all gaskets and cushions must be disposed off since they are permanently deformed by compression during service.

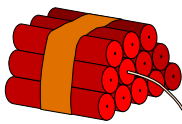

DANGER

DO NOT under any circumstances reuse glass or gasketing items previously in service, since they can cause leaks or high stress points resulting in glass breakage and severe personal and property damage. Glass that is broken is dangerous and should be disposed of in a safe manner determined by the user.

7.2 Reassembly

To prepare for installation of new glass, clean the gasket seating. Exercise extreme care to avoid gouging or scarring gasket seating surfaces. Failure to prepare the gasket surfaces will result in leaks and/or glass breakage.

Check flatness of each glass seating surface of the sight window by using a known flat piece of the same size glass and a thickness gauge. Surfaces must be flat within 0.005 inch. If the glass seating surfaces cannot be restored to this tolerance, the entire sight window must be disposed of and replaced. If tolerances are met, proceed with re-assembly of the sight window.

Before installation, inspect the replacement glass for imperfections. During inspection, and during any subsequent handling of the glass, keep the glass from contacting other surfaces. Bumping or sliding of glass against other surfaces can result in glass breaking, scratching or chipping. Install the new glass by following the procedure in Section 4.

8.0 Telephone Assistance & Equipment Return

If you are having difficulty with your Sight Window, notify your local Archon distributor, or call the factory direct **(845) 368-3600** and ask for the Sight Window product manager. To help us assist you more effectively, please have as much of the following information as possible when you call:

- ◇ Model #
- ◇ Name of the company from whom you purchased the Circular Sight Window
- ◇ Invoice # and Date
- ◇ Process Media
- ◇ Operating Temperature
- ◇ Operating Pressure
- ◇ Brief description of the problem
- ◇ Troubleshooting procedures that failed

You must obtain a Return Authorization (RA.) number from Archon before returning anything. Failure to do so will result in the unit being returned to you, without being tested, freight collect. To obtain a RA. #, the following information (in addition to that above) is needed:

- ◇ Reason for Return
- ◇ Person to contact at your company
- ◇ "Ship-To" address

There is a minimum charge of \$50.00 for evaluation of non-warranty units. You will be contacted before we repair the unit if there will be any additional charges. If you return a unit that is covered by the warranty, but is not defective, the minimum charge will apply.

9.0 Sectional view of Sight glass

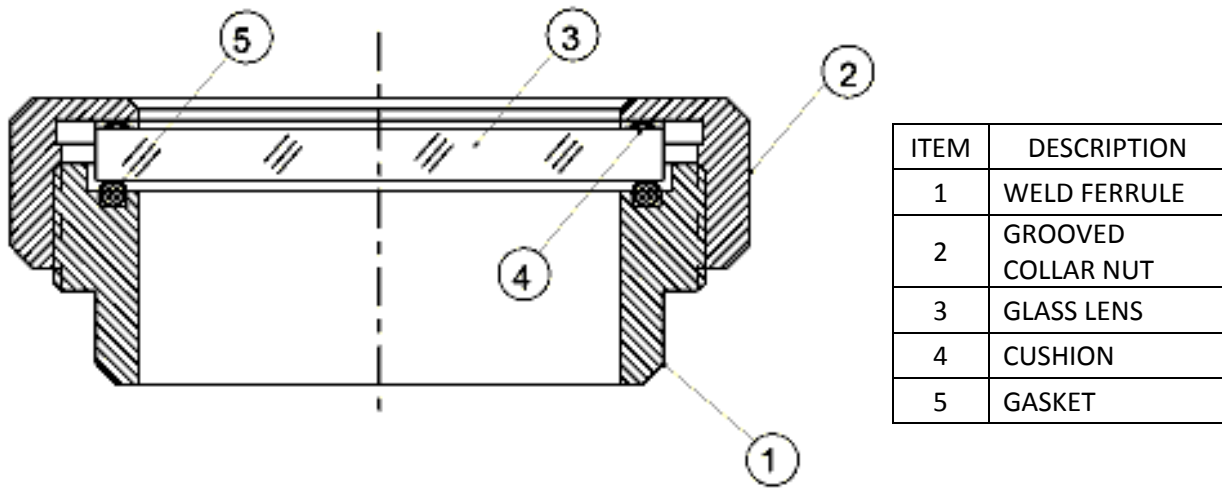

FIGURE 1