

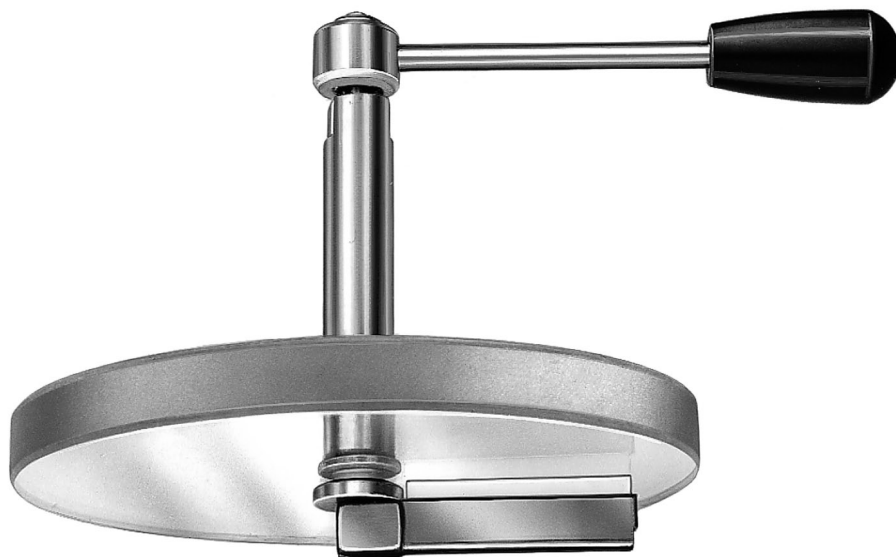

ARCHON Industries, Inc.

Centrally Operated Window Wiper Type “W”



Installation / Operation / Maintenance Instruction

Instruction #: **1020 rev A**
Issued: **5/02/2005**
Approved: **K. Mayer P.E.**

357 Spook Rock Road
Bldg # 1 – 505
Suffern, NY 10901



Tel.: (845) 368-3600
Fax: (845) 368-3040
sales@archonind.com

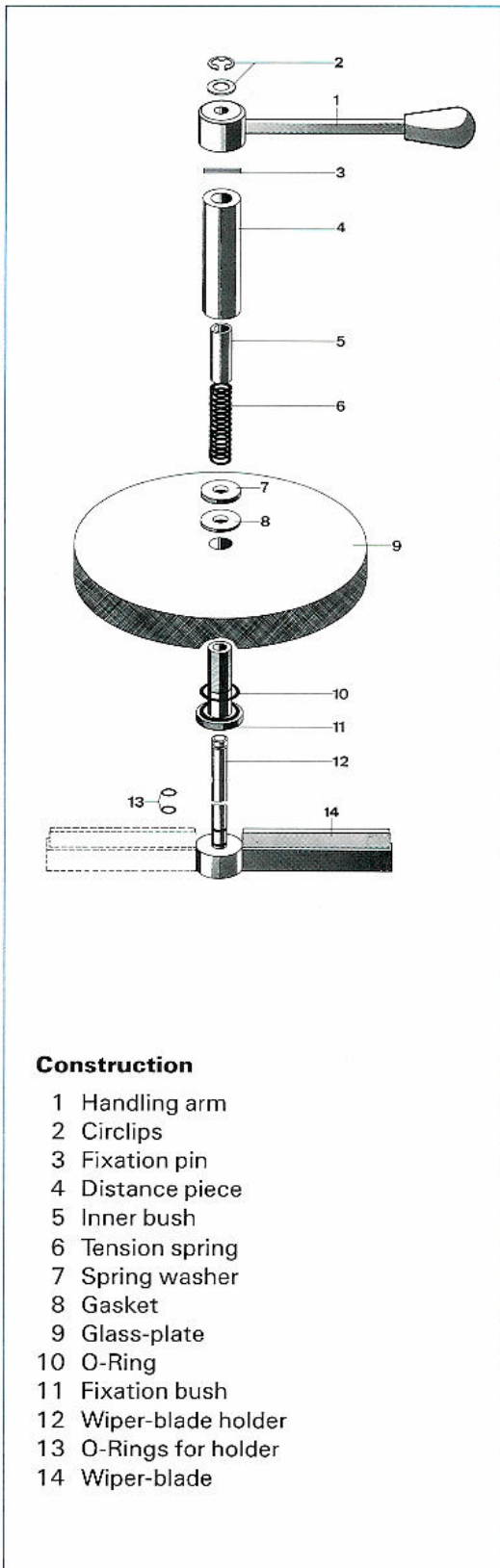

I. APPLICATION

Series "W" window wipers are built into circular sight glass to prevent crystallization of the media inside the vessel onto inner side of the glass plate or to keep the side glass free of dust and / or dirt.

They are mounted into round glass plates with a centric hole 10.5 mm diameter. The wiper includes a single radial arm wiper blade. The wiper is turned by a radially mounted handling arm, fitted with a slip-clutch bearing.

II. STORAGE AND HANDLING

All units should be inspected for damage upon receipt. Units should be stored where they will be protected from physical damage. Particular care should be taken to protect threaded end connections, seals, bushings and blade from damage.

III. PREPARATION

1. Before starting installation, ensure that glass disc is not damaged.
2. Check that all necessary parts are on-hand. Each assembly should include the parts as on the drawing.
3. Wiper must be installed prior to installing sight-glass, gaskets and exterior glass cover.

IV. INSTALLATION

1. Insert O-ring (10) into the Fixation bush (11).
2. Insert the Fixation bush (11) into the bore hole of the glass disc. Any markings of the glass disc should be on the opposite side of the wiping surface.
3. Pull the Gasket (8) and the Washer (7) onto the Fixation bush (11) and place them on the outer face of the glass disc (9).

4. Screw the Distance piece (4) onto the Fixation bush (11), secure it with e.g. “Loctite” and finger-tighten to seat the O-ring (10) on the glass disc (9). Finger tighten. Using a wrench on the flats of the distance piece (4), while holding the round of the fixation bush (11) with pliers (taking extreme care not to twist against the glass or scratch the fixation bush), turn the distance piece clockwise one-quarter turn.
5. Put the wiper Blade (14) into the wiper blade Holder (12). Grease the axis of the wiper blade Holder (12) with Silicone based grease and insert it into the Fixation bush (11) until the wiper Blade is not in contact with the glass disc (9).
6. Pull the Tension spring (6) and the Inner bush (5) over the axis of the wiper blade Holder (12). The Tension spring (6) sits on the Fixation bush (11) and is inside the Distance piece (4). The Inner bush (5) sits on the Tension spring (6).
7. Compress the Tension spring (6) by exercising a slight pressure with the Inner bush (5) until the drilling in the axis of the wiper blade holder (12) is appearing over the end of the Inner bush (5). Insert the Fixation pin (3) into the drilling of the axis of the wiper blade holder (12).
8. Mount the Handling arm (1) onto axis of the wiper blade Holder (12), so the wiper Blade (14) turns clockwise. Fix the washer and Circlips (2) onto the axis of the wiper blade holder (12).

V. PRECAUTIONS & WARNINGS:

- 1.** The correctly mounted sight glass disc with wiper mechanism may only be used within the temperature & pressure ranges specified below. If the given limits are not respected, the glass discs may fail.
- 2.** Avoid spraying of the sight glasses with cold fluid – failure could result.
- 3.** The drive / spindle housing should be periodically checked and tightened, if necessary to ensure good seal. **DO NOT ATTEMPT TO TIGHTEN WHILE THE VESSEL IS UNDER PRESSURE OR VACUUM. WAIT UNTIL THE VESSEL IS AT ATMOSPHERIC PRESSURE BEFORE ATTEMPTING TO TIGHTEN THE WIPER.**
- 4.** The wiper handle should be operated clock-wise. It is important to avoid undue vertical force – either up or down – or sideways force on the wiper shaft as such forces will impair the wiper operation and could lead to failure of the glasses.

- 5.** If required, necessary steps have to be undertaken that no transfer of static electricity from the operator onto the wiper mechanism can occur.

VI. PRESSURE & TEMPERATURE RATING OF WIPER “W” ASSEMBLIES:

Glasabmessungen Dimensions du verre Glass dimensions Dimensiones del cristal	Ø Di (mm)	Ø Dm (mm)	Max. zulässiger Betriebsdruck Pression de service max. autorisée Authorised max. working pressure Presión máxima de trabajo (bar)
Ø 84 x 10 mm	66	73,4	4,0
Ø 99 x 15 mm	81	87,9	6,0
Ø 114 x 15 mm	100	106,9	5,0
Ø 125 x 15 mm	100	113,5	4,5
Ø 147 x 15 mm	125	133,4	3,0
Ø 150 x 15 mm	125	138,5	3,0
Ø 150 x 15 mm*	136	145	1,0
Ø 175 x 15 mm	150	163,5	2,0
Ø 200 x 15 mm	175	188,5	1,5
Ø 225 x 15 mm*	205	215	0,5
Ø 250 x 15 mm	225	238,5	1,0
Ø 250 x 19 mm	225	238,5	1,5

Di = Free view

Dm = Unsupported diameter

Maximum authorized temperature:

- ? Wipers with Tempered Soda Lime glass discs: **302° F [150° C]**
- ? Wipers with Tempered Borosilicate glass discs:
 - ✎ **Silicone** wiper blade: **356° F [180° C]**
 - ✎ **Teflon** wiper blade: **392° F [200° C]**