



**ARCHON Industries, Inc.**

# Rectangular Sight Windows

Models

**RLG-L - Reflex**

**TLG-L -  
Transparent**

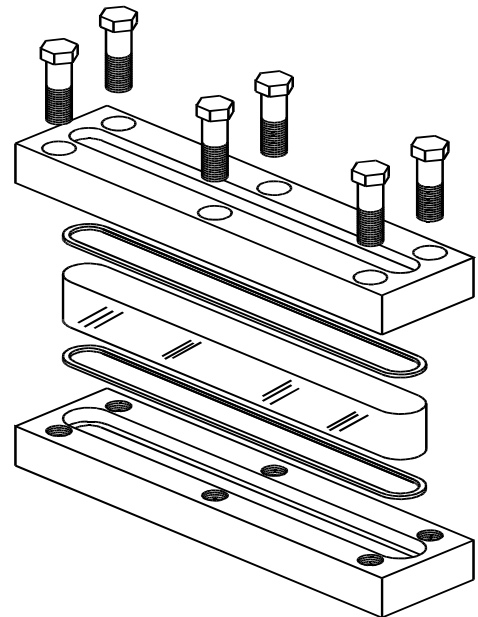

## **Installation / Operation / Maintenance Instruction**

Instruction#: **1003.1**  
Issued: **05/23/12**  
Approved: **F. Bongiorno**  
**Engineering Manager**

---

357 Spook Rock Road  
Bldg # 1 – 505  
Suffern, NY 10901



Tel.: (845) 368-3600  
Fax: (845) 368-3040  
sales@archonind.com

## **TABLE OF CONTENTS**

## **PAGE**

Product Warranty -----	3
1.0 About the Manual -----	4
2.0 Introduction -----	4
2.1 System Description -----	4
3.0 Available Models-----	5
4.0 Installation -----	5
4.1 Preparation For Units Requiring Welding -----	6
4.2 Welding -----	7
4.3 Assembling/Re-assembling Sight Windows -----	7
5.0 Operation -----	8
6.0 Maintenance -----	8
6.1 Maintenance Procedures-----	9
6.2 Troubleshooting -----	10
7.0 Removal/Disassembly/Re-assembly-----	10
Disassembly -----	7.1
7.2 Re-assembly -----	10
8.0 Telephone Assistance -----	11
9.0 Parts View -----	12

## **TABLES AND FIGURES**

Figure 1	Bolt Torquing Sequence -----	13
Table 1	Torque Values for Rectangular Sight Windows -----	13

## **PRODUCT WARRANTY**

Archon Industries Inc., warrants its products as designed and manufactured by Archon to be free of defects in material and workmanship for a period of one year after the date of installation or eighteen months after the date of manufacture, whichever is earliest. Archon will, at its option, replace or repair any products that fail during the warranty period due to defective material or workmanship.

Prior to submitting any claim for warranty service, the owner must submit proof of purchase to Archon and obtain written authorization to return the product. Thereafter, the product shall be returned to Archon in Suffern, New York, with freight prepaid.

This warranty shall not apply if the product has been disassembled, tampered with, repaired or altered outside of the Archon factory, or if it has been subjected to misuse, neglect or accident.

Archon's responsibility hereunder is limited to repairing or replacing the product at its expense. Archon shall not be liable for loss, damage, or expenses directly or indirectly related to the installation or use of its products, or from any other cause or for consequential damages. It is expressly understood that Archon is not responsible for damage or injury caused to other products, building, property or persons, by reason of the installation or use of its products.

**THIS IS ARCHON'S SOLE WARRANTY AND IN LIEU OF ALL OTHER WARRANTIES, EXPRESSED OR IMPLIED WHICH ARE HEREBY EXCLUDED, INCLUDING IN PARTICULAR ALL WARRANTIES OF MERCHANTABILITY OR FITNESS FOR A PARTICULAR PURPOSE.**

This document and the warranty contained herein may not be modified and no other warranty, expressed or implied, shall be made by or on behalf of Archon unless modified or made in writing and signed by the President or a Vice President of Archon.

## 1.0 About the Manual

This manual has been prepared as an aid and guide for personnel involved in installation and maintenance. All instructions must be read and understood thoroughly before attempting any installation, operation or maintenance.



## WARNING

**Failure to follow instructions could result in breakage of the sight window glass, resulting in fluid escaping from the vessel and fragmenting glass. Always wear safety glasses when installing, servicing or operating a sight window. Failure to follow precautions can result in personal injury and property damage.**

## 2.0 Introduction

Archon Industries, Inc.'s Rectangular Sight Window is designed to increase the viewing length beyond that of conventional sight windows.

The Rectangular Sight Window provides an elongated glass window for convenient fluid monitoring. The window assists the observer by creating a monitoring port for fluid process volumes, directions, and reactions without exposing the liquid to the external environment.

Archon's models are available with a flat or radius pad.

## 2.1 System Description

The Archon Rectangular Sight Window consists of five basic components. Each component may vary slightly, depending on the desired physical and mechanical properties for the indicator. Use the parts view in Section 9.

**Cover** - the cover provides a machined surface in which the glass and cushion are protectively seated. The cover provides an effective means of compressing the gasket between the glass and weld pad using threaded fasteners.

**Lower Pad** - the lower pad provides a mounting surface to place on the vessel wall and a base for studs to be inserted. The lower pad provides a machined surface to which the gasket makes a seal.

**Glass Plate** - the glass provides a window for vessel fluid observation.

**Gaskets** - when the nuts are torqued to their proper values, the gaskets are compressed between the glass and weld pad to tightly seal the gap and prevent leaking.

**Studs/Nuts** - the studs are used as a means to mechanically compress the assembly to the proper torque value.

### 3.0 Available Models

Archon offers the standard Rectangular Sight Window model RLG with a flat weld pad or a radius weld pad. Standard materials of construction for the metal housing are SA-515 Gr 70 Steel and SA-240 Gr STS 316L. Standard glass is tempered borosilicate; standard gasket material is non asbestos (NA). Alternate available gasket materials are Buna N, Neoprene, Viton, Grafoil and Teflon.

### 4.0 Installation

Upon receipt of the Archon Rectangular Sight Window, check all components carefully for damage which may have been incurred during shipping. **IMPORTANT: If damage is evident or suspected, do not attempt installation. Notify your carrier immediately and request a damage inspection.**

Archon's standard Rectangular Sight Window unit is comprised of set cover(s), set cushion(s), glass(es) and gasket(s), (1) welding pad, (1) identification nameplate, and set of mounting studs and nuts.

Confirm that the information on the identification tag conforms to the size, model, and performance data on the purchase order and the actual operating conditions at the installation site.

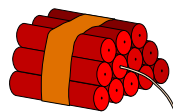

**DANGER**

**Exceeding the design ratings or application's data limits can**

**cause the glass to break, the unit to leak or sudden release of pressure. Do not exceed the design ratings for each particular unit. Failure to keep operating conditions below design ratings may result in severe personal injury and property damage.**

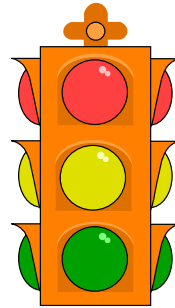

**CAUTION**

**Only qualified, experienced personnel who are familiar with sight window equipment and thoroughly understand the implications of the tables and all the instructions should install the Rectangular Sight Window. Failure to read and comply to the following instructions could result in personal injury or property damage.**

#### **INSPECTION:**

- 1) Examine the glass to see that it is free of scratches, chips or other imperfections.
- 2) Ensure that the weld pad and cover have been cleaned and are free of any foreign material.
- 3) Ensure that the vessel connection area has been cleaned and is free of any foreign material.

## LOCATIONS PRECAUTIONS:

Locate the Rectangular Sight Window:

- 1) where it can be easily seen;
- 2) away from areas where objects may be dropped, thrown or generally allowed to contact the glass;
- 3) protected from dust, grit or other objects that could damage the glass;
- 4) protected from external thermal shock , such as high temperature application being exposed to a cold air blast or cold water wash.

### 4.1 Preparations Before Welding

Welding must adhere to all applicable local and national codes and recognized safety practices. Use dimensional sheets or Archon product proposal to obtain dimensional information for the size and model. Use this information to secure a work bench no shorter than the Rectangular Sight Window, and sufficiently wide to lay out parts as they are removed.

If the Rectangular Sight Window is pre-assembled with glass and gaskets, remove the cover, the bolting, the glass and gaskets. Lay the Rectangular Sight Window on its weld pad. Hold unit firmly while loosening and removing nuts. Carefully remove and set aside the cover, cushions, glass, shields (if any), and gaskets. These components can be reinstalled after welding **in this instance only** because the sight window has not been torqued during assembly.

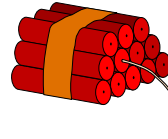

**DANGER**

**Extreme care should be used when disassembling the Rectangular Sight Window to avoid damaging the cushions, glass, shields, or gaskets. Damaging any of these components could result in glass breakage with sudden release of pressure and contained fluid, causing severe personal and property damage.**

### 4.2 Welding

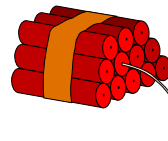

**DANGER**

**DO NOT proceed with any welding while the vessel is in operation. Pressure increases the likelihood of the glass plate breaking and contents spraying out of the vessel. A vessel must be relieved of all pressure or vacuum, allowed to reach ambient temperature and drained or purged of all fluids before conducting installation or repair welding. Failure to follow this procedure could result in severe personal injury and property damage.**

Use the pad as a template and mark the vessel wall at the top and the bottom of the slot with a pencil.

Drill 2 holes in the vessel wall corresponding to the top and bottom of the slot in the weld pad (Drill two holes for a single section weld pad, four holes

for a two-section weld pad. Use a 1/2" – 5/8" drill.

Reinstall the cover directly on top of the weldpad and torque to 25 ft-lbs. Use extreme caution so that gouging or scarring of the glass seating surfaces on the weld pad and cover surface is avoided.

**FOR AN EFFECTIVE SEAL AND BEST PERFORMANCE, THE GASKET SEAT MUST REMAIN FLAT AFTER WELDING.**

Hold the Rectangular Sight Window in position and tack weld the weld pad to the vessel wall with six spot welds equidistance apart around the circumference of the welding pad. Complete welding of the sight window to the tank or vessel wall by making short passes approximately 1 1/2" long and alternating from side to side and end to end until the entire circumference of the weld pad is welded in place.

Allow the weldment several minutes to cool, then remove the bolting and the spacer

If desired, a slot in the vessel wall may be made at this time, corresponding to the slot in the weld pad itself. This is an option that may be necessary depending upon the application: reflex glass weld pad or transparent glass weld pad.

Reflex glass is used to read one liquid level only in a 2-phase system (e.g. oil/vapor interface).

Transparent glass is used to read liquid/liquid interfaces in 3-phase systems(e.g. water/ hydrocarbon/vapor). In general, when reflex glass is used, it

is not necessary to slot the vessel wall to match the slot in the weld pad; the two holes, one at the top of the slot and one at the bottom of the slot in the pad are sufficient. If transparent glass is used, the vessel wall should be slotted.

### **4.3 Assembling/Re-assembling**

Refer to the diagram in Section 9 for component identification assistance and position.

- 1) Carefully remove the glass plate from the shipping package and place in a safe area.
- 2) Clean any material from gasket seating cavity.
- 3) Place and align the gasket in the seating cavity of the weld pad.
- 4) Apply oil or anti-seize to threads of the studs.
- 5) Place a rubber band around the circumference of the glass to properly center the glass.
- 6) Carefully place shield (if any) and glass plate on the gasket until they rest level on the gasket. Position shield between glass and gasket.
- 7) Place cushion on top of the glass so that it lines up with the edges of the glass plate.
- 8) Carefully place the cover over the welding pad studs and ease the cover onto the cushion until it is seated with the studs visible.
- 9) Place the nuts on the studs and tighten with fingers.

10) Using a torque wrench, tighten the bolts to the proper value in a sequence as shown in the figure below. Tighten bolts in increments of 3 ft/lbs or 50% of torque value, whichever is smaller.



**Torquing under pressure yields incorrect torque and increases the likelihood of the glass plate breaking and contents spraying out of the vessel. The sight window must be relieved of all pressure or vacuum, and allowed to reach ambient temperature. The vessel must be drained or purged of all fluids before re-torquing. Failure to follow this procedure could result in severe personal injury and property damage.**

#### **BOLT TORQUE CHECK:**

Bolt torque is vital to the proper operation of a Rectangular Sight Window. Bolt torque should be checked after initial installation, and periodically thereafter, to ensure that the unit is in compliance with the torque values described in Section 4 (tighten in the proper sequence - see Figure 1).

#### **5.0 Operation**

Before initializing sight window operation, check that all installation procedures have been completed. Use only qualified, experienced personnel who are familiar with sight window equipment and thoroughly understand

the implications of the tables and all the instructions. Check that the bolts have been torqued to their proper limits as stated in Section 4. Check that all connections are pressure tight and the glass is clean and free of any damage.

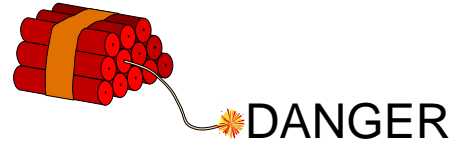

**Sight windows should be brought into service slowly to avoid excessive shock or stress on the glass. Rapid pressurization of a sight window can cause glass breakage/fragmentation and fluid leakage. Failure to take proper precautions could result in severe personal or property damage.**

#### **6.0 Maintenance**

Use only qualified, experienced personnel who are familiar with sight window equipment and thoroughly understand the implications of the tables and all the instructions.

Create a maintenance schedule for each specific installation of a Rectangular Sight Window. On all inspections, regularly check the following items:

- 1) glass for cleanliness and signs of damage or wear,
- 2) sight window for signs of leakage at gaskets or along welds,
- 3) sight window for signs of internal or external corrosion, and
- 4) bolt torque values (see Section 4).



Use only qualified experienced personnel who are familiar with sight window equipment and thoroughly understand the implications of the tables and all the instructions.

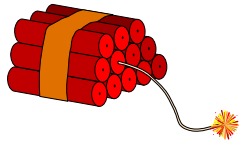

**DANGER**

**DO NOT proceed with any maintenance while the sight window is in operation. Pressure increases the likelihood of the glass plate breaking and contents spraying out of the vessel. A sight window in service must be relieved of all pressure or vacuum, allowed to reach ambient temperature and the vessel drained or purged of all fluids before conducting maintenance. Failure to follow this procedure could result in severe personal injury and property damage.**

## 6.1 Maintenance Procedures

**GLASS** should be given regular and careful attention. Keep glass clean using a commercial glass cleaner and a soft cloth. Inspect the surface of the glass for any clouding, etching or scratching or physical damage such as bruises, checks or corrosion. Glass that is damaged is weakened and may break under pressure. Shining a light at approximately a 45° angle will aid in detecting some of these conditions. Typical damaged areas will glisten more brightly than the surrounding glass because the light is reflected. Detection of any damage, problem areas or surface wear is sufficient

evidence to take the sight window out of service. **DO NOT** proceed with operations until the glass has been replaced with a glass replacement kit following the assembly instructions in Section 4.

**SHIELDS** showing any sign of clouding, wear, or deterioration is an indication that the sight window glass has been or could soon become exposed to the contained fluid. Immediately take the sight window out of service and replace the shield, glass, and gasket following the assembly instructions in Section 4.

**GASKET LEAKS** must be repaired immediately. **DO NOT** proceed with operations until gaskets have been replaced by following the assembly instructions in Section 4.

**CORROSION** may occur if the user has selected an improper material for the Rectangular Sight Window application. It is the responsibility of the user to choose a material of construction compatible with both the contained fluid and the surrounding environment. If internal or external corrosion are present, an investigation must immediately be performed by the user. It may be necessary to contact an authorized Archon distributor to better determine the origin of the corrosion.

## 6.2 Troubleshooting

Problem: glass or shield becomes etched or clouded in service  
Cause: fluid being handled is not compatible with the glass or shield material  
Solution: replace the glass and/or shield

Problem: glass continually breaks in service

Cause: warped body as a result of mechanical or thermal stresses

Solution: reduce the stress and replace sight window

## 7.0 Removal/Disassembly/Re-assembly

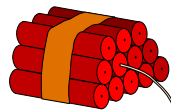

**DANGER**

**DO NOT proceed with any removal or disassembly while the sight window is in operation. Pressure increases the likelihood of the glass plate breaking and contents spraying out of the vessel. A sight window in service must be freed of all pressure or vacuum, allowed to reach ambient temperature, and the vessel drained or purged of all fluids before proceeding. Failure to follow this procedure could result in severe personal injury and property damage.**

### 7.1 Disassembly

The Rectangular Sight Window should be disassembled by loosening the nuts in the sequence denoted in Section 4. Remove the cover, cushion, glass, and gaskets from the indicator using the appropriate safety precautions. Once a sight window has been disassembled, all glass must be disposed of because of wear; and all gaskets and cushions must be disposed of since they are permanently deformed by compression during service.

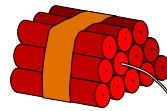

**DANGER**

**DO NOT under any circumstances reuse glass or gasketing items previously in service, since they can cause leaks or high stress points resulting in glass breakage and severe personal and property damage. Glass that is broken is dangerous and should be disposed of in a safe manner determined by the user.**

### 7.2 Re-assembly

To prepare for installation of new glass, clean the gasket seating surfaces on the welding pad and cover. This should be done using a soft metal scraper (preferably brass) to remove all burrs, rust and remnants of the previous gasket. Exercise extreme care to avoid gouging or scarring gasket seating surfaces. Failure to prepare the gasket surfaces will result in leaks and/or glass breakage.

Check flatness of each glass seating surface of the sight window by using a known flat piece of the same size glass and a thickness gauge. Surfaces must be flat within 0.005 inch. If the glass seating surfaces cannot be restored to this tolerance, the entire sight window must be disposed of and replaced. If tolerances are met, proceed with re-assembly of the sight window.

Before installation, inspect the replacement glass for imperfections. During inspection, and during any subsequent handling of the glass, keep the glass from contacting other surfaces. Bumping or sliding of glass

against other surfaces can result in glass breaking, scratching or chipping. Install the new glass by following the procedure in Section 4.

## 8.0 Telephone Assistance

### Telephone Assistance & Equipment Return

If you are having difficulty with your Rectangular Sight Window, notify your local Archon distributor, or call the factory direct (845) 368-3600 and ask for the Sight Window product manager. To help us assist you more effectively, please have as much of the following information as possible when you call:

- ◇ Model #
- ◇ Name of the company from whom you purchased the Rectangular Sight Window
- ◇ Invoice # and Date
- ◇ Process Media
- ◇ Operating Temperature
- ◇ Operating Pressure
- ◇ Brief description of the problem

- ◇ Troubleshooting procedures that failed

You must obtain a Return Authorization (R. A.) number from Archon before returning anything. Failure to do so will result in the unit being returned to you, without being tested, freight collect. To obtain a R. A. #, the following information (in addition to that above) is needed:

- ◇ Reason for Return
- ◇ Person to contact at your company
- ◇ "Ship-To" address

There is a minimum charge of \$50.00 for evaluation of non-warranty units. You will be contacted before we repair the unit if there will be any additional charges. If you return a unit that is covered by the warranty, but is not defective, the minimum charge will apply.

**TYPICAL TORQUING SEQUENCE**

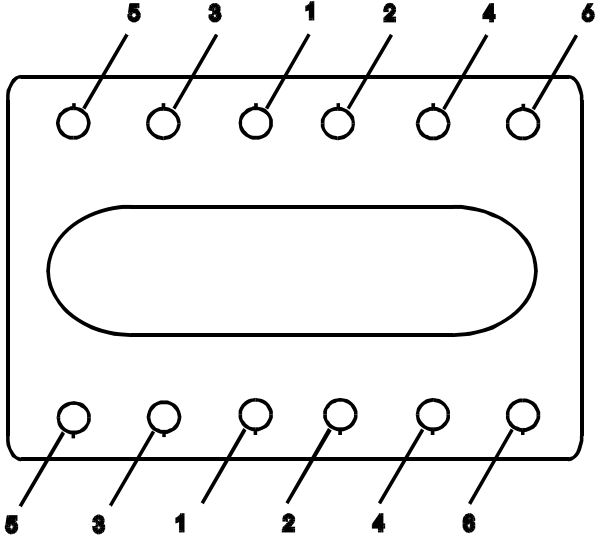

FIGURE 1

Model	Sizes	Glass	Torque
TLG RLG	All sizes	Transparent	12 - 18 ft. lbs. (Lubricated)
		Reflex	

**Torque Values for Rectangular Sight Windows**

TABLE 1

## 9.0 Parts Drawing

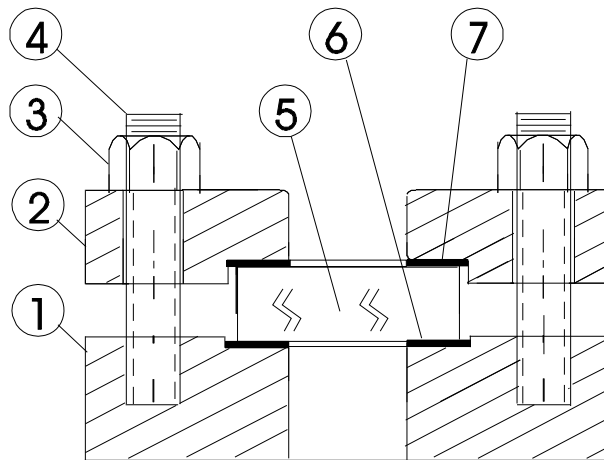

- 1- weld pad
- 2- cover
- 3- nut
- 4- stud
- 5- glass
- 6- gasket
- 7- cushion

---

357 Spook Rock Road  
Suffern, NY 10901



(845) 368-3600  
FAX (845) 368-3040