



## MODEL AKF-S - THREADED SIGHT FLOW INDICATOR

### Description:

ARCHON Model AKF-S sight flow indicators are designed for process observation in piping systems. They are widely used in the general processing industry for viewing presence of flow, solids, color or turbidity. They are available in various materials of construction including carbon steel, stainless steel and nickel alloys, and are for use in vacuum and pressure applications. Standard bodies are made from high quality castings. End connections are standard NPT threads.

### Operating conditions:

Full ANSI 150# class pressure rating applies to sizes up to 2" NPT.

### Options and accessories:

- Plain style — maximizes visibility.
- Drip tube style — mounted vertically for low-flow observation.
- Flapper style—hinged for flow indication of clear fluids. May help determine relative flow rate.
- Rotator style—spinning action indicates flow.

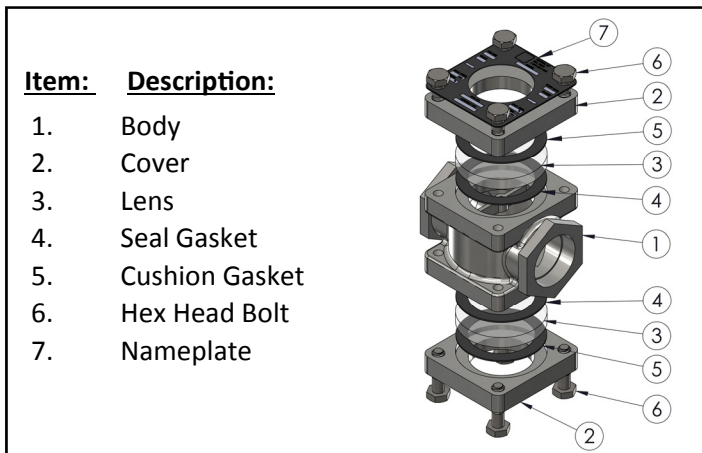
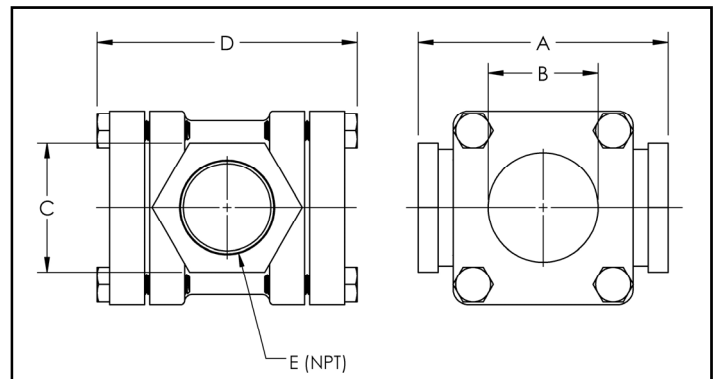

**Item: Description:**

- |    |                |
|----|----------------|
| 1. | Body           |
| 2. | Cover          |
| 3. | Lens           |
| 4. | Seal Gasket    |
| 5. | Cushion Gasket |
| 6. | Hex Head Bolt  |
| 7. | Nameplate      |

Size (E)	"A"	"B"	"C"	"D"	Weight (lb)
1/2"	3-3/4"	1-1/4"	1-1/2"	4-1/8"	4.3
3/4"	3-3/4"	1-1/4"	1-1/2"	4-1/8"	4.3
1"	4-1/4"	1-1/2"	2"	4-3/4"	7
1-1/2"	5-1/2"	2-1/4"	2-1/2"	5-1/2"	11
2"	6-1/4"	2-3/4"	3-1/4"	6-5/8"	20

### Ordering Information:\*

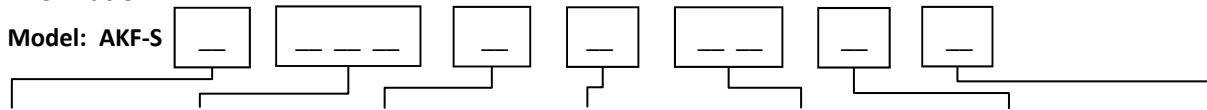

Indicator:	Size:	Cover:	Body:	Seal Gasket:	Lens:	Configuration:
D: Drip tube	005: 1/2"	A: Carbon	A: Steel—A216	05: Neoprene	A: Tempered	Blank: Standard
F: Flapper	007: 3/4"	Steel	WCB	07: Expanded	Borosiliced	A—Z: Special
P: Plain	010: 1.0"	C: 316 SS	C: SS—A351 CF8M	PTFE	C: Quartz	
R: Rotator	015: 1.5"		J: Alloy C276—	11. Grafoil GHR	E: Acrylic	
	020: 2.0"		A494 CW12MW	13: Garlock 3300		
	030: 3.0"					

\*Contact ARCHON for additional material options, temperature ratings or special configurations.