



ARCHON Industries, Inc.

**Model EX99-LED Explosion Proof
Luminaire - Instruction No. 1015-2 July 2017**

**Installation / Operating / Maintenance
Instructions**

1. Suitability

1.1 This luminaire is suitable, when installed and operated in accordance with these instructions, for use in the following locations as defined by the National Electrical Code:

Class	Division	Groups
I	1	C and D
I	2	C and D

1.2 This luminaire is rated for Temperature Code T6 for a maximum ambient temperature of 40°C.

2. Installation

2.1 Install and use in accordance with all applicable electrical and fire safety codes.

2.2 Ensure electrical service leads are properly protected against mechanical damage.

2.3 **CAUTION:** To reduce the risk of fire or explosion, do not install where the marked operating temperature exceeds the ignition temperature of the hazardous atmosphere.

2.4 **CAUTION:** Mount this luminaire at any angle between the glass lens facing down and the glass lens facing horizontally. Do not mount this luminaire with the lens facing at any angle above the horizontal. See figure 1.

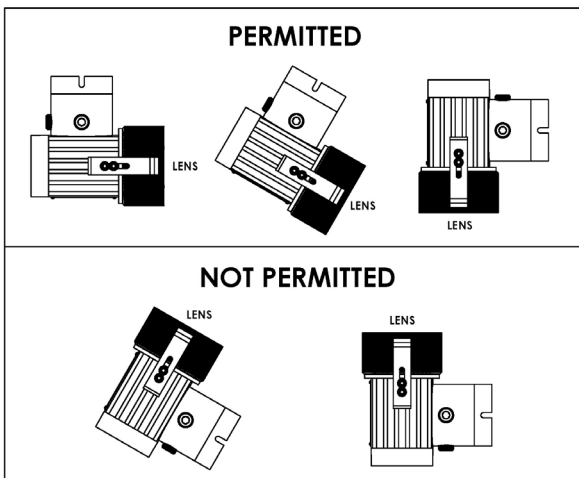

Figure 1 – Operating Position

2.5 **CAUTION:** Use wires rated for 105°C minimum for supply connections.

3. Operation

3.1 **CAUTION:** To reduce the risk of ignition of hazardous atmospheres, disconnect the luminaire from the electrical supply circuit before opening any of the covers.

3.2 Do not energize luminaire if the glass lens is cracked or broken, or if the lens cap is not screwed on tightly.

3.3 Ensure that the lens is securely held in the luminaire before energizing the electrical supply circuit. The lens should not be free to move when properly installed. The lens cap must be fully tightened onto the body to properly secure the lens.

3.4 Ensure that all covers are tightly closed when the luminaire is in operation.

4. Driver Removal and Installation

Removal

4.1 The LED driver can be accessed and removed from the rear of the unit as follows.

4.2 Remove the rear cover and slide the LED driver out of the LED heatsink.

4.3 With the driver removed, disconnect the input and output connectors to the driver.

Installation

4.4 Connect the input and output leads of the new driver to the appropriate connectors making sure that the new driver is of the same type and rating as provided by ARCHON. *To reduce the risk of inverting driver wiring, the input and output connectors are not identical.*

4.5 With the wire bundle carefully packaged and secured to the driver using the recommended wire tie, carefully place back into the LED heatsink. *See figure 3 for illustration.*

4.6 Install the rear cover and test the luminaire with the appropriate AC input voltage.

5. Removal of LED Assembly

5.1 The LED assembly is provided as a single unit which includes: LED heatsink, light source (COB LED), reflector assembly, LED driver and wiring.

5.2 First unscrew the rear cover and disconnect the AC leads from the LED driver. These leads are black and white with an orange connector.

5.3 Although not required, if necessary, the cable entry gland located in the wiring compartment can be removed by unscrewing it from the body.

5.4 With the AC wires disconnected, remove the front lens cap and slide the full LED assembly directly out the front of the unit.

5.5 To install a new LED assembly, proceed to section 6 of this document.

6. Installation of LED Assembly

- 6.1 Be sure to follow all recommended practices prior to removing the new LED assembly from its ESD protective packaging.
- 6.2 Verify that the correct equipment is available prior to starting work. This includes an ESD matt and wrist band which should be worn at all times.
- 6.3 If previously removed, ensure that the cable entry gland is reinstalled in the wiring compartment and fully seated with the bottom.
- 6.4 To install a new LED assembly, insert the new assembly into the front of the unit until it is fully seated. Carefully install the lens cap assembly until it bottoms out with the body. Secure hand tight only.
- 6.5 From the rear of the unit, carefully remove the driver and the wire bundle from within the LED heatsink by pulling gently on the assembly until it is removed. Note the position of the wires for proper reassembly.
- 6.6 Identify the driver AC input leads - black and white leads with an orange connector.
- 6.7 Connect the AC input leads from the cable entry gland to the driver AC input connector. *Note: Do not tamper with the LED driver output connector. This connection supplies DC power to the LED COB.*
- 6.8 With the wire bundle carefully packaged and secured to the driver using the recommended wire tie, carefully place back into the LED heatsink paying special attention to how the wires are seated.
- 6.9 Prior to installing the rear cover, check that the O-ring (item 9) is properly installed and that there is no visible damage to the O-ring. Confirm that there are no pinched wires and install the rear cover until it is seated flush with the body. Secure hand tight only.
- 6.10 Test the light with the appropriate AC input voltage to ensure it is operating properly.
- 6.11 If at any point assistance is required, contact Archon Industries for guidance.

PRECAUTIONS:

- Verify the shipped contents are correct. Do not proceed with the installation if damage is found. Contact ARCHON Industries in such an event.
- Verify that the correct seals, mounting brackets, accessories, parts and all other necessary hardware are available prior to starting work.
- All work should be performed by a qualified electrician in accordance with the National Electrical Code, applicable local codes and ordinances. Always check with the Authority Having Jurisdiction (AHJ) to confirm acceptable procedures.
- Confirm the operating voltage of your system found on the manufacturers label of the luminaire and driver/power supply.
- Do not operate beyond the maximum recommended temperature.
- Do not look directly into the LED light source.
- Do not touch the LED light source.
- Do not allow contact of any type with the LED light source.
- Do not modify or operate with dimmers or other non-approved control circuits unless the luminaire is equipped with that option.
- This luminaire is designed to operate in an open environment. Operating in enclosed spaces without air circulation will reduce its lifespan and may void the warranty.
- Do not operate luminaire in packing carton.
- Power must be off during the installation. Turn off and lock-out the breaker for the circuit. Affix a warning label on the electrical panel before proceeding.
- Use supplied original packing for protection when transporting luminaire.
- Do not put excessive force on wire connectors.

ITEM NO.	DESCRIPTION	MATERIAL	QTY.
1	BODY, EX99-LED	ALUMINUM	1
2	LED ASSEMBLY	----	1
3	LENS CAP, EX99-LED	ALUMINUM	1
4	LENS, EX99-LED	BOROSILICATE	1
5	REAR COVER, EX99-LED	ALUMINUM	1
6	COVER, WIRING COMPARTMENT	ALUMINUM	1
7	CONDUIT CONNECTION – 1/2" NPT	STEEL	3
8	O-RING (56343-003) SHORE A 70	BUNA	1
9	O-RING (56M2.5080-003) SHORE A 70	BUNA	2
10	O-RING (56152-003) SHORE A 70	BUNA	1

See the following page for isometric exploded views (Figures 2 & 3)

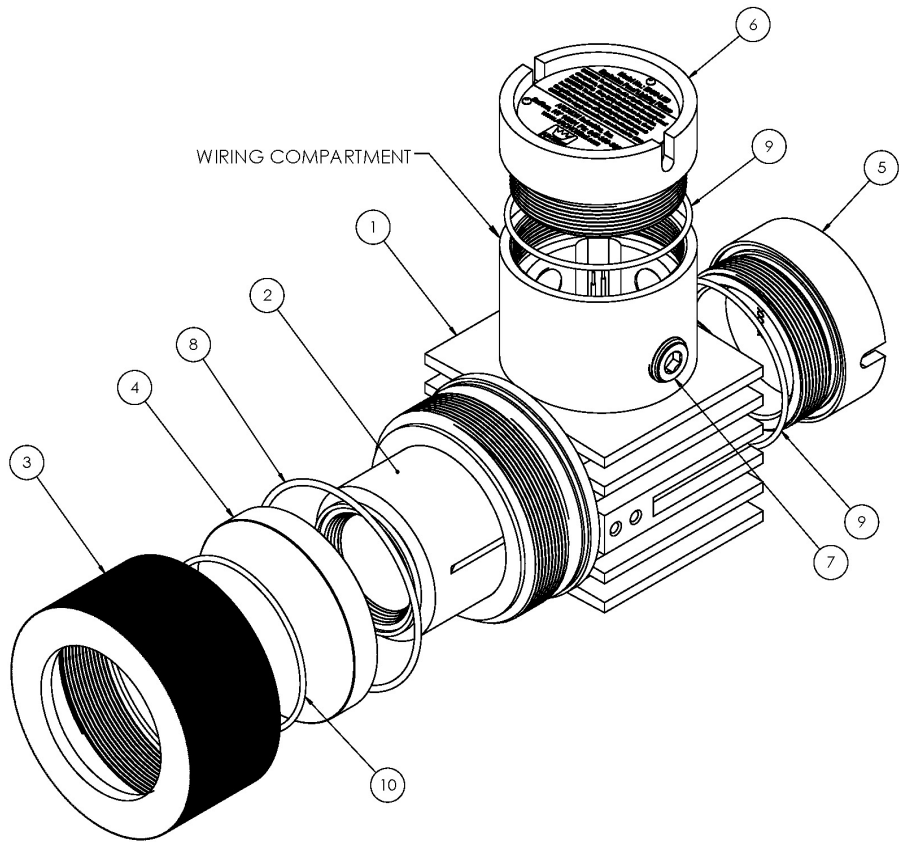

Figure 2 - EX99-LED Luminaire

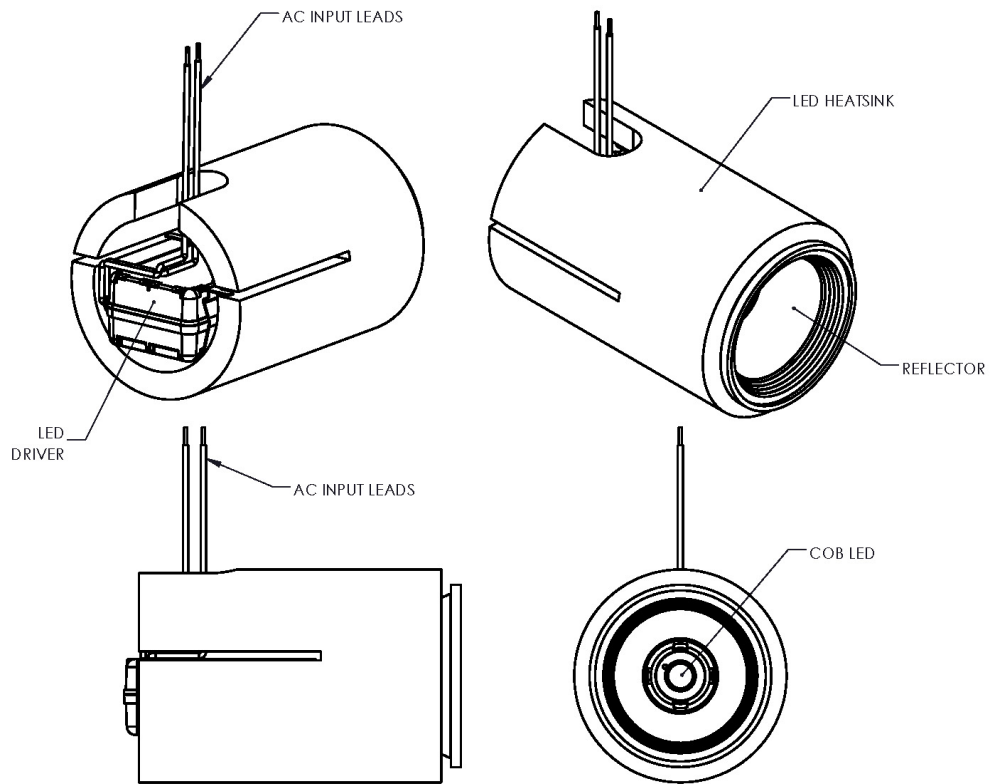

Figure 3 - EX99-LED Assembly