



MODEL RLG-OB - WELD PAD OBROUND SIGHT GLASS

Description:

Model RLG-OB sight glasses are designed for welding into ASME Code and non-code pressure vessels, piping or tank walls. They are available in various materials of construction, and are for use in vacuum and pressure applications. Custom designs are available for higher pressure ratings, special sizes, and cylindrical radiused weld pads.

Model RLG-OB sight glass materials conform to ASME Boiler & Pressure Vessel code.

Operating conditions:

Standard units are designed for full vacuum and up to 150 psig. Higher pressure ratings are available upon request. Temperature rating is limited by the gasket material and/or lens material.

Options and accessories:

RLG-OB sight glasses can be supplied with the following options and accessories:

- Lighting units for hazardous or non-hazardous locations.
- Spray wash systems.
- Internal radius for rubber lining.



ARCHON Model RLG-OB complete assemblies shown.

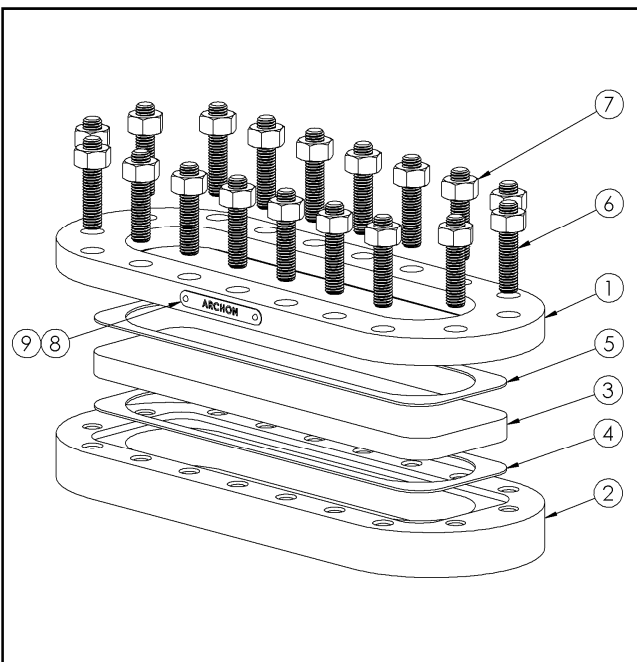

ARCHON Model KB exploded view.

Materials:

<u>Item:</u>	<u>Description:</u>	<u>Material specification:</u>
1	Cover Flange	304L, 316L, carbon steel, ASME SA material
2	Weld Pad	304L, 316L, carbon steel, ASME SA material
3	Lens	Tempered borosilicate, tempered soda lime, quartz, polycarbonate, acrylic
4	Seal Gasket	Non-asbestos, EPDM, nitrile, silicone, PTFE, Viton®, graphite
5	Cushion Gasket	Non-asbestos, PTFE, graphite
6	Stud	Stainless steel, alloy steel. ASME SA material
7	Hex nut	Stainless steel, alloy steel. ASME SA material
8, 9	Nameplate	Stainless steel



MODEL RLG-OB - WELD PAD OBROUND SIGHT GLASS

Size	"A"	"B"	"C"	"D"	"E"	Bolting
1 x 06	1"	6"	3.63"	7.19"	1.25"	(10) x 1/2"
1 x 12	1"	12"	3.63"	15"	1.25"	(14) x 1/2"
1 x 18	1"	18"	3.63"	21"	1.25"	(20) x 1/2"
1 x 24	1"	24"	3.63"	27"	1.25"	(28) x 1/2"
2 x 06	1"	6"	5"	9"	1.25"	(10) x 1/2"
2 x 12	2"	12"	5"	15"	1.25"	(14) x 1/2"
2 x 18	2"	18"	5"	21"	1.25"	(20) x 1/2"
2 x 24	2"	24"	5"	27"	1.25"	(26) x 1/2"
3 x 12	3"	12"	6"	16"	1.25"	(18) x 1/2"
3 x 18	3"	18"	6"	22"	1.25"	(24) x 1/2"
3 x 24	3"	24"	6"	28"	1.25"	(28) x 1/2"
4 x 12	4"	12"	7"	17"	1.25"	(20) x 1/2"
4 x 18	4"	18"	7"	23"	1.25"	(26) x 1/2"
4 x 24	4"	24"	7"	29"	1.50"	(36) x 1/2"
6 x 12	6"	12"	9"	17"	1.50"	(16) x 1/2"

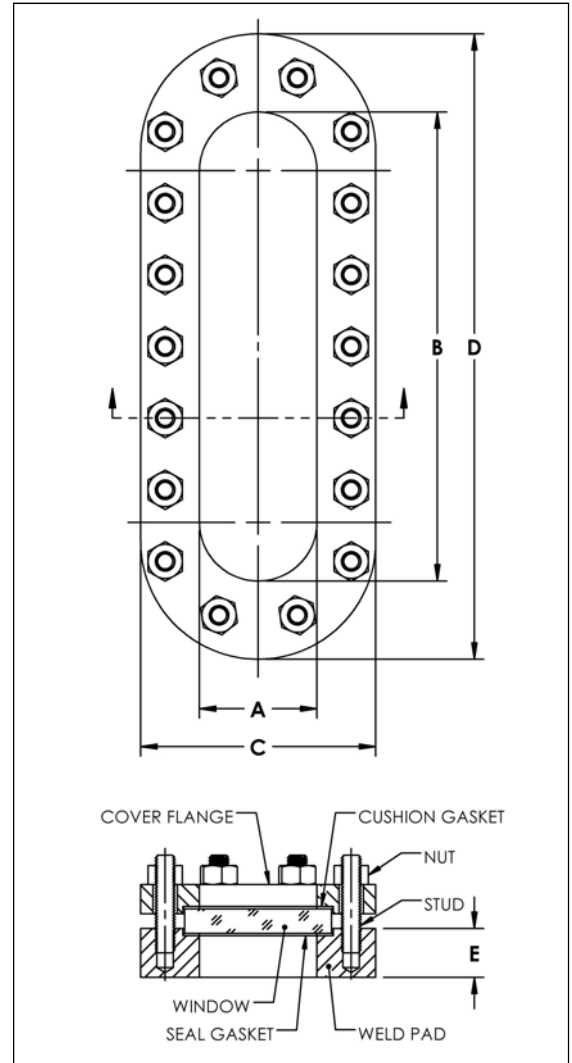

Standard Pressure rating for most sizes: 150 psig / full vacuum.

Ordering Information:*

Model: RLG**OB**

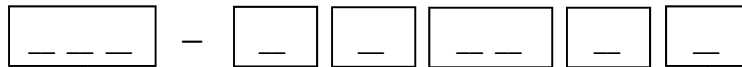

Size:	Cover:	Weld Pad:	Seal Gasket:	Lens:	Configuration:
106 312	A: Carbon Steel	A: Carbon Steel	01: Non-asbestos	A: Tempered Borosilicate	Blank: Standard
112 318	B: 304/304L SS	B: 304/304L SS	02: EPDM	B: Tempered Soda Lime	A—Z: Special
206 324	C: 316/316L SS	C: 316/316L SS	03: Nitrile	C: Quartz	
212 412	D: 317/317L SS	D: 317/317L SS	06: Silicone	D: Polycarbonate	
218 418	E: 2205 Duplex	E: 2205 Duplex	07: Expanded PTFE	E: Acrylic	
224 424	G: AL6XN	G: AL6XN (6 Moly)	09: Viton®		
	H: Alloy C22	H: Alloy C22	11: Graphite		
	J: Alloy C276	J: Alloy C276			
	K: Alloy 20	K: Alloy 20			

*Contact ARCHON for additional material options, temperature ratings or special configurations.