

ARMORED LIQUID LEVEL GAUGES

Large Chamber Gauges Model RLC and TLC

ARCHON models RLC and TLC are designed to give a more accurate reading for liquids that have a tendency to surge or boil, than could be achieved with the standard gauges.

Here are some of the qualities that make ARCHON armored gauges superior to our competitors gauges:

- The liquid chamber is made from exceptionally heavy tubing 2" ID x 3-3/4"OD with a 7/8" wall thickness.
- The liquid chamber is recessed to hold each individual gauge glass and gasket snugly, eliminating any possible movement by internal pressure.
- The covers are fitted to the liquid chamber with stud bolts, making assembly or replacement of glasses and gaskets much easier and faster than with curved U-bolts and through bolts.

The covers are drop forged, machined to fit the contour of the glass and provides full support for the front cushion gasket. It is bolted to the face of the liquid chamber with the glass and gaskets in between.

Gaskets used are of the finest quality, uniform in thickness and accurately die-cut. Our standard gasket material is compressed non-asbestos, but can be interchanged with alternate material depending on the liquid being used.

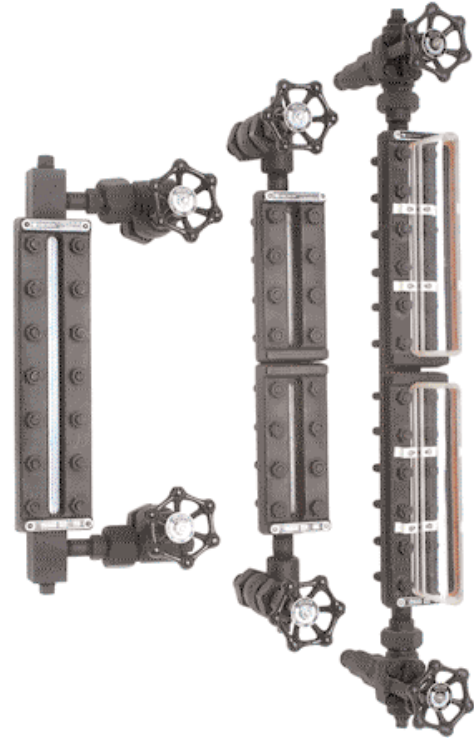

sales@ARCHONind.com

Pressure and Temperature Ratings: ARCHON Reflex Gauges Model RLC						
Size Gauge	100°F	200°F	300°F	400°F	500°F	600°F
1 x 1	2000	1900	1850	1750	1550	1300
1 x 2	1950	1850	1750	1600	1450	1270
1 x 3	1900	1800	1700	1550	1400	1250
1 x 4	1850	1750	1650	1500	1350	1220
1 x 5	1800	1700	1600	1450	1300	1200
1 x 6	1750	1650	1550	1400	1250	1170
1 x 7	1700	1600	1500	1350	1200	1150
1 x 8	1600	1500	1400	1300	1150	1100
1 x 9	1500	1400	1350	1250	1100	1050

All Gauges Hydrostatic Tested: 1.5 times 100°F Rating

Pressure and Temperature Ratings: ARCHON Transparent Gauges Model TLC						
Size Gauge	100°F	200°F	300°F	400°F	500°F	600°F
1 x 1	1500	1400	1300	1150	1000	850
1 x 2	1450	1350	1250	1100	970	830
1 x 3	1400	1300	1200	1070	940	800
1 x 4	1350	1250	1150	1040	900	770
1 x 5	1300	1200	1100	1000	870	750
1 x 6	1250	1150	1050	950	830	720
1 x 7	1200	1100	1000	900	800	700
1 x 8	1100	1050	950	850	750	650
1 x 9	1000	950	850	750	650	550

All Gauges Hydrostatic Tested: 1.5 times 100°F Rating

Correction Factor Table-To be Applied to the 100% Ratings Listed Above

% of Rating	100%	75%	50%	25%
Chamber	Carbon Steel, 304SS and 316SS	Monel	Bronze	
Gasket Material Liquid Side	Teflon Lo-Flo, Non-Asbestos		Pure Teflon, Kel-F Shields	
Gasket Material Liquid & Cover Side	Non-Asbestos		Teflon Lo-Flo	Pure Teflon
Optional Features	Non-Frost Extensions (Max. Temp. 100°F)			

ARMORED LIQUID LEVEL GAUGES

We can furnish these gauges in single section sizes 1 through 9 or in multiple section type with one-piece liquid chamber for the entire length of the gauge.

The liquid chamber can be supplied in Steel or Stainless Steel to meet specific requirements.

REFLEX GAUGES - This gauge type is equipped with flat reflex glass comprised of reflecting prisms which cause the liquid inside to appear black in color. The space above appears silvery in direct contrast assuring a distinct reading of the liquid level.

TRANSPARENT GAUGES - This gauge type is equipped with two flat plain glass sections; one on either side of the liquid chamber. This allows light to pass through the gauge permitting clear observation of liquid level, color and clarity.

Plastic or MICA shields can be furnished when handling caustic substances, acids or media corrosive to glass.

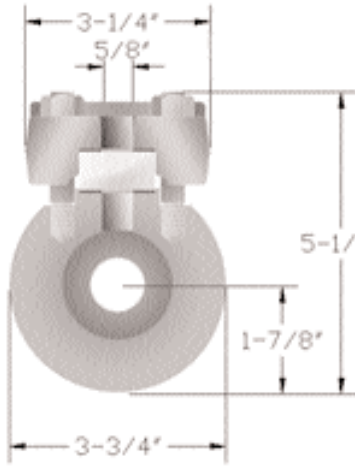

ARCHON Model RLC Large Chamber Unit

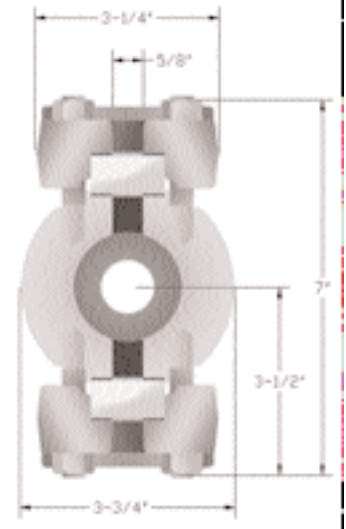

ARCHON Model TLC Large Chamber Unit

5 Section Gauge Size 9 Glass

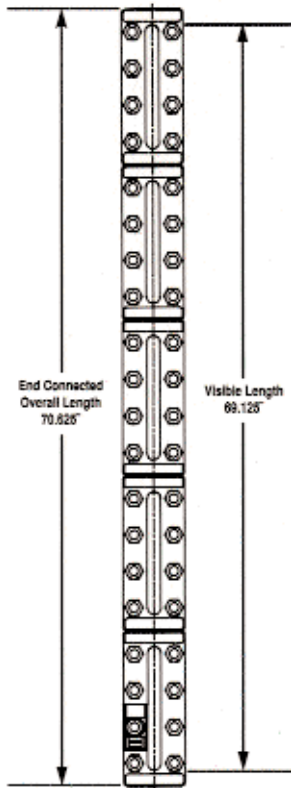

Sections	Glass Size	Visible Length		End Connected Overall Length	
		inch	mm	inch	mm
1	1	3.750	95	5.250	133
1	2	4.750	121	6.250	159
1	3	5.750	146	7.250	184
1	4	6.750	171	8.250	210
1	5	7.875	200	9.375	238
1	6	9.125	232	10.625	270
1	7	10.250	260	11.750	298
1	8	11.875	302	13.375	340
1	9	12.625	321	14.125	359
2	4	15.000	381	16.500	419
2	5	17.250	438	18.750	476
2	6	19.750	502	21.250	540
2	7	22.000	559	23.500	597
2	8	25.250	641	26.750	679
2	9	26.750	679	28.250	718
3	6	30.375	772	31.875	810
3	7	33.750	857	35.250	895
3	8	38.625	981	40.125	1019
3	9	40.875	1038	42.375	1076
4	7	45.500	1156	47.000	1194
4	8	52.000	1321	53.500	1359
4	9	55.000	1397	56.500	1435
5	7	57.250	1454	58.750	1492
5	8	65.375	1661	66.875	1699
5	9	69.125	1756	70.625	1794
6	8	78.750	2000	80.250	2038
6	9	83.250	2115	84.750	2153
7	8	92.125	2340	93.625	2378
7	9	97.375	2473	98.875	2511
8	8	105.500	2680	107.000	2718
8	9	111.500	2832	113.000	2870
9	8	118.875	3019	120.375	3058
9	9	125.625	3191	127.125	3229
10	8	132.250	3359	133.750	3397
10	9	139.750	3550	141.250	3588