



ARCHON model KB-WN Weld Neck Sightglasses

Section
Bulletin
Issued
Page

2003
1001
01/08
014

ARCHON model KB-WN Weld Neck Sightglasses

KB-WN are weld neck units designed to be welded onto pipe ends or into tanks or vessels. The lower flange is a standard ANSI 150# weld neck flange. Higher rated units are also available (300# and 600#).

Material certification is furnished with all KB-WN units.

Available options include:

- Low Pressure Wiper
- High Pressure Wiper
- Hazardous and Non-Hazardous Lighting Units
- Spray Wash Systems

Standard sightglass lens material is Tempered Borosilicate(500°F) and Tempered Soda Lime(400°F). If your operating temperature requirement is above 550°F, we offer Vycor or Quartz glass.

Available pipe sizes range from 1" to 8" standard and other sizes are available upon request

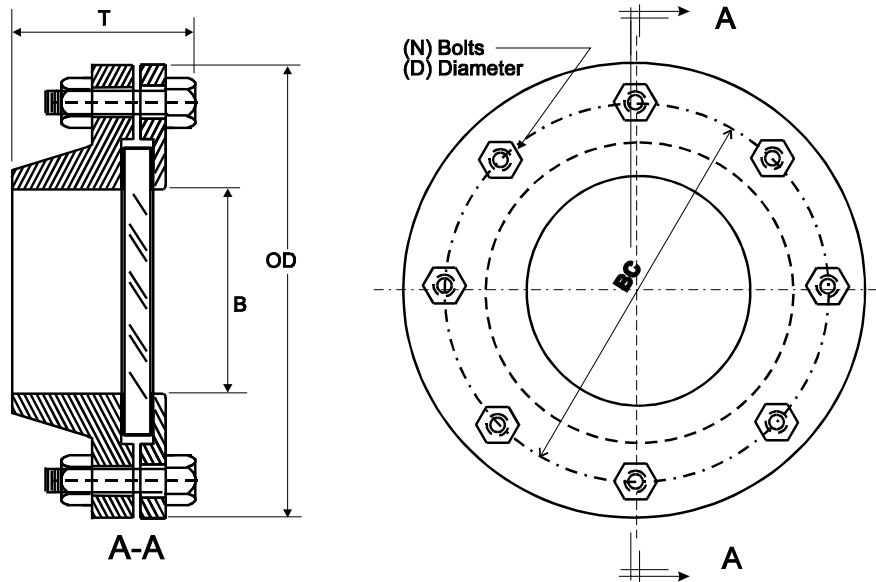

Model	OD	B	BC	N	D	T	Maximum Pressure
KBWN-1	4-1/4"	1"	3-1/8"	4	1/2"	3.2"	150 psig
KBWN-1-1/2	5"	1-1/2"	3-7/8"	4	1/2"	3.5"	150 psig
KBWN-2	6"	2"	4-3/4"	4	5/8"	3.6"	150 psig
KBWN-2-1/2	7"	2-1/2"	5-1/2"	4	5/8"	4.2"	150 psig
KBWN-3	7-1/2"	3"	6"	4	5/8"	4.5"	150 psig
KBWN-4	9"	4"	7-1/2"	8	5/8"	4.8"	150 psig
KBWN-5	10"	5"	8-1/2"	8	3/4"	5.5"	150 psig
KBWN-6	11"	6"	9-1/2"	8	3/4"	5.9"	150 psig
KBWN-8	13-1/2"	8"	11-3/4"	8	3/4"	6.4"	150 psig

(800) 554-1394

www.ARCHONind.com

ARCHON Industries, Inc.
357 Spook Rock Road, Suffern NY 10901
www.ARCHONind.com

fax: (845) 368-3040

sales@ARCHONind.com