

**NOTES:**

1. FASTENERS CONFORM TO THE REQUIREMENTS OF ASME B&PV CODE, SECTION VIII
2. FLANGE MATERIAL CONFORMS TO THE REQUIREMENTS OF ASME B&PV CODE, SECTION VIII
3. PRESSURE RATING: 150 PSI/FV @500 °F. TEMPERATURE RATING MAY BE LIMITED BY GASKET SELECTION.

REVISIONS				
REV	DESCRIPTION	DATE	DRAWN	APPROVED
A	INITIAL RELEASE	02/15/17	J.CUSTY	
B	UPDATED DRAWING	06/15/17	J.CUSTY	

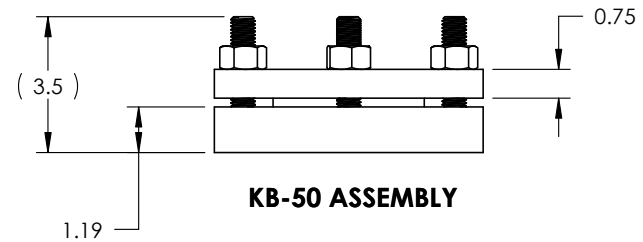
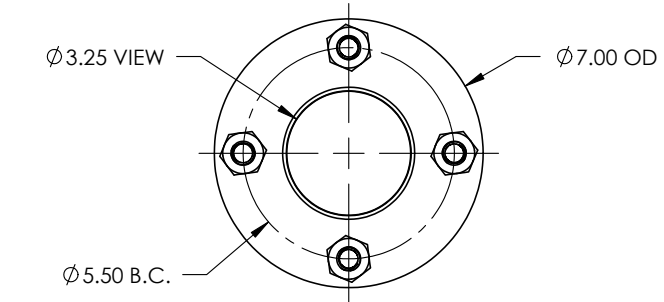
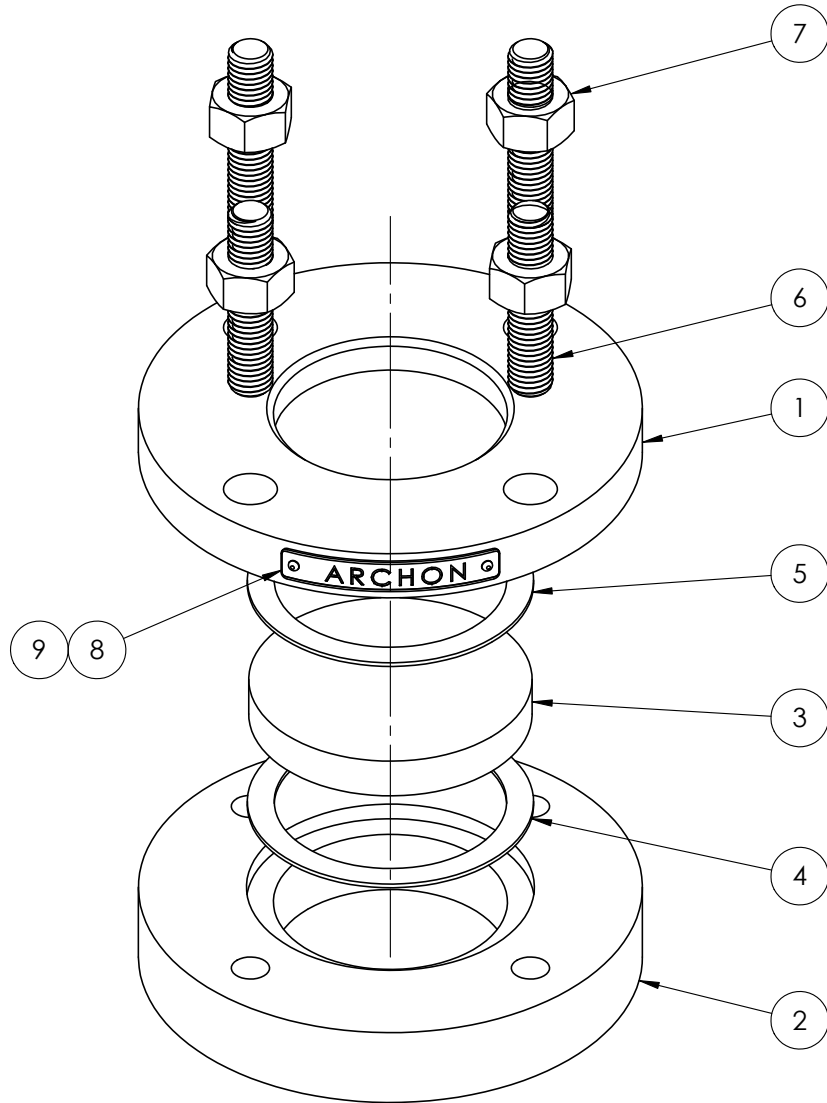

ITEM	DESCRIPTION	QTY
9	DRIVE SCREW	2
8	LABEL, ARCHON	1
7	HEX NUT, HEAVY, 5/8-11 UNC	4
6	STUD, 5/8-11 UNC X 3" LG	4
5	GASKET, CUSHION	1
4	GASKET, SEAL	1
3	LENS	1
2	WELD PAD	1
1	COVER FLANGE	1

**BILL OF MATERIAL**

UNLESS OTHERWISE SPECIFIED	DR	JPC	DATE 02/15/17
DIMENSIONS IN INCHES	CHKD		DATE
DECIMALS      FRACTIONS	APVD		DATE
X ± .030      ± 1/64	APVD		DATE
XX ± .015      ANGLES			
XXX ± .010      ±.5			
REMOVE ALL BURRS AND BREAK SHARP EDGES .02 MAX	MATERIAL: PER ORDER		
SURFACE ROUGHNESS ✓	FINISH:		
DIMENSIONS AFTER PLATING OR COATING			
THIRD ANGLE PROJECTION	DO NOT SCALE DRAWING		

**ARCHON INDUSTRIES, INC.**  
 357 SPOOK ROCK ROAD  
 SUFFERN, NY 10901  
 (845) 368-3600  
 FAX (845) 368-3040

TITLE: <b>ASSEMBLY, KB-50</b>		
SIZE <b>A</b>	SCALE:	SHEET 1 OF 1
	DWG. NO. <b>KB-50-ASM</b>	REV <b>B</b>