

ARCHON INDUSTRIES, INC.

Sight Flow Indicators

300# & 600# ANSI – Models:

Flanged: AKF-FM, AKF-FH

Threaded: AKF-SM, AKF-SH

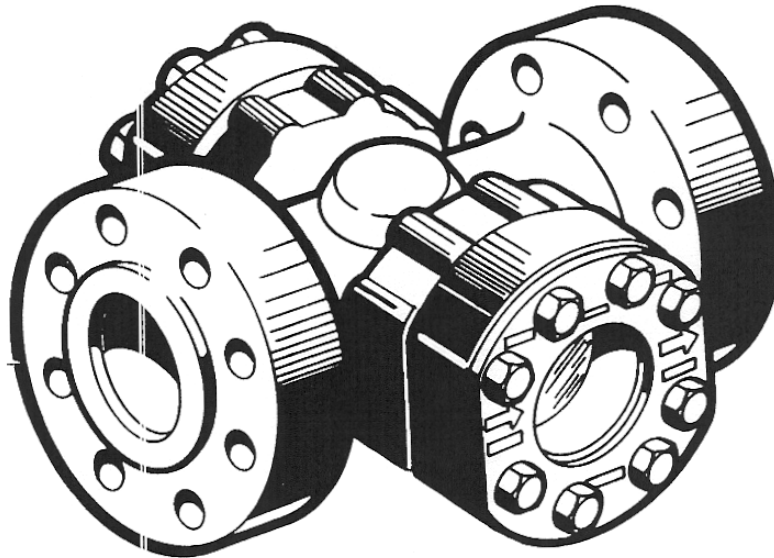

Installation / Operation / Maintenance Instructions

ARCHON INDUSTRIES, INC.

357 Spook Rock Road # I-505

Suffern, NY 10901

Tel.: (845) 368-3600

Fax: (845) 368-3040

Printed in U.S.A.

Instruction #:

Issued:

Approved:

1021 Rev A.

May 15, 2012

Engineering Mgr

Table of Contents

1.0 Product Warranty	3
2.0 About the Manual	3
3.0 Introduction	4
3.1 Features and Specifications.....	4
3.2 Available Models	4
3.3 Design Ratings PSIG at Max & Min Operating Temperatures.....	4
3.4 Application Data	4
4.0 Inspection and Performance Confirmation	6
4.1 Receiving Inspection	6
4.2 User's Rating Inspection.....	6
5.0 Installation	6
5.1 Effect of Related Piping and Precautions.....	7
5.2 Positioning of Specific Model.....	8
5.3 Bolt Torque.....	8
6.0 Operation	8
6.1 Pre-Operation Check.....	8
6.2 Hydrostatic Pressure Test.....	9
6.3 Operating.....	9
7.0 Maintenance	9
7.1 Preventative Maintenance	10
7.2 Maintenance Procedures	10
7.3 Troubleshooting for Soundness of Glass	12
7.4 Removal-Disassembly-Reassemble	12
8.0 Telephone Assistance	14

Tables and Figures

Page

Table 1	Maximum Design Ratings for Units with Tempered Glass	3
Figure 1	Bolt Torque Values	8
Figure 2	Bolt Tightening Sequence	8
Figure 3	Pipe Thread Taping.....	8
Figure 4	Bolt Loosening Sequence.....	12
Figure 5	Exploded Parts View.....	15

1.0 Product Warranty

ARCHON INDUSTRIES, INC. warrants its products as designed and manufactured by ARCHON to be free of defects in material and workmanship for a period of one year after the date of installation or eighteen months after the date of manufacture, whichever is earliest. ARCHON will, at its option, replace or repair any products, which fail during the warranty period due to defective material or workmanship.

Prior to submitting any claim for warranty service, the owner must submit proof of purchase to ARCHON and obtain written authorization to return the product. Thereafter, the product shall be returned to ARCHON in Port Chester, New York, with freight prepaid.

This warranty shall not apply if the product has been disassembled, tampered with, repaired or altered outside of the ARCHON factory, or if it has been subjected to misuse, neglect or accident.

ARCHON does not have control over the manner in which its sight flow indicator is handled, installed, or used, and ARCHON cannot and does not warrant or guarantee that a sight flow indicator is suitable or compatible with the user's specific application.

ARCHON's responsibility hereunder is limited to repairing or replacing the product at its expense. ARCHON shall not be liable for loss, damage, or expenses directly or indirectly related to the installation or use of its products, or from any other cause or for consequential damages. It is expressly understood that ARCHON is not responsible for damage or injury caused to other products, building, property or persons, by reason of the installation or use of its products.

THIS IS ARCHON'S SOLE WARRANTY AND IN LIEU OF ALL OTHER WARRANTIES, EXPRESSED OR IMPLIED WHICH ARE HEREBY EXCLUDED, INCLUDING IN PARTICULAR ALL WARRANTIES OF MERCHANTABILITY OR FITNESS FOR A PARTICULAR PURPOSE.

This document and the warranty contained herein may not be modified and no other warranty, expressed or implied, shall be made by or on behalf of ARCHON unless modified or made in writing and signed by the President or a Vice President of ARCHON.

2.0 About the Manual

This manual has been prepared as an aid and guide for personnel involved in installation and maintenance. All instructions must be read and understood thoroughly before attempting any installation, operation or maintenance.

△ WARNING △

Failure to follow instructions could result in a malfunction or breakage of the indicator, resulting in fluid escaping from the unit and fragmenting glass. Always wear safety glasses when installing, servicing or operating a sight flow indicator. Failure to follow precautions can result in personal injury and property damage.

3.0 Introduction

3.1 Features and Specifications

ARCHON's Sight Flow Indicators have been designed for the observation of the flow stream in a process pipeline. They are available in a variety of models, sizes and connection styles. The user should refer to ARCHON dimension sheets to determine specific models and connection styles available.

These Sight Flow Indicators permit visual monitoring of:

- ◆ liquid interfaces - change in level or evidence of liquid in the viewing area
- ◆ foam interfaces - change in level or evidence of foam in the viewing area
- ◆ fluid movement - change in direction or volume
- ◆ color - change in tint or hue
- ◆ clarity - change in opacity, brightness or purity

3.2 Available Models

AKF-FMP	Plain Indicator / 300# ANSI Flanged Body
AKF-FMR	Rotator Indicator / 300# ANSI Flanged Body
AKF-FMF	Flapper Indicator / 300# ANSI Flanged Body
AKF-FMD	Drip Tube Indicator / 300# ANSI Flanged Body
AKF-SMP	Plain Indicator / 300# ANSI Threaded Body
AKF-SMR	Rotator Indicator / 300# ANSI Threaded Body
AKF-SMF	Flapper Indicator / 300# ANSI Flanged Body
AKF-SMD	Drip Tube Indicator / 300# ANSI Flanged Body
AKF-FHP	Plain Indicator / 600# ANSI Flanged Body
AKF-FHR	Rotator Indicator / 600# ANSI Flanged Body
AKF-FHF	Flapper Indicator / 600# ANSI Flanged Body
AKF-FHD	Drip Tube Indicator / 600# ANSI Flanged Body

3.3 Design Ratings PSIG & Maximum & Minimum Operating Temperatures

To determine the maximum allowable working pressure for a specific temperature within the design limits stated above, the user should refer to ARCHON dimension sheets, or when provided, the specifically stated design limits on an ARCHON product proposal.

3.4 Application Data

NOTE: For specific application data within the above ranges, consult the ARCHON product proposal data for the specific model and size sight flow indicator, or request ARCHON to supply the applicable Technical Data Bulletin.

Maximum Design Ratings for 300# ANSI Units with Tempered Glass (PSIG)

Body Material	Temperature Rating	Gasket Material						
		Teflon®	Non-Asbestos	Grafoil®	Viton®	Kel-F®	Neoprene	Buna N
Carbon Steel	-20°F to 100°F	740	740	740	740	740	740	740
	at 250°F							665
	at 300°F						665	
	at 400°F				635	635		
	at 500°F	600	600	600				
316 SS	-20°F to 100°F				720			
	-65°F to 100°F						720	720
	-120°F to 100°F	720						
	-150°F to 100°F		720					
	-300°F to 100°F			720		720		
	at 250°F							590
	at 300°F						560	
	at 400°F				515	515		
at 500°F	480	480	480					

Maximum Design Ratings for 600# ANSI Units with Tempered Glass (PSIG)

Body Material	Temperature Rating	Gasket Material						
		Teflon®	Non-Asbestos	Grafoil®	Viton®	Kel-F®	Neoprene	Buna N
Carbon Steel	-20°F to 100°F	1480	1480	1480	1480	1480	1480	1480
	at 250°F							1335
	at 300°F						1315	
	at 400°F				1270	1270		
	at 500°F	1200	1200	1200				
316 SS	-20°F to 100°F				1440			
	-65°F to 100°F						1440	1440
	-120°F to 100°F	1440						
	-150°F to 100°F		1440					
	-300°F to 100°F			1440		1440		
	at 250°F							1180
	at 300°F						1120	
	at 400°F				1030	1030		
at 500°F	955	955	955					

TABLE 1

⚠ WARNING ⚠

Never exceed these design ratings or application data limits. Exceeding design ratings or application data can cause serious personal injury to personnel.
IMPORTANT: Exceeding design ratings or application data can result in property damage.

4.0 Inspection and Performance Confirmation

4.1 Receiving Inspection

Upon receipt of sight flow indicator, check all components carefully for damage incurred in shipping. If damage is evident or suspected, do not attempt installation. Notify carrier immediately and request a damage inspection.

4.2 User's Rating Inspection

The user is to confirm:

1. That the sight flow indicator model number and pressure/temperature rating stamped on nameplate (163) conforms to the description on the user's purchase order.
2. That the operating conditions described in the purchase order agree with the actual operating conditions at the installation site.
3. That the actual operating conditions at the installation site are within the application data shown on the ARCHON Technical Data Bulletin or product or product proposal referred to above.
4. That the materials of construction of the sight flow are compatible with both the contained fluid and surrounding atmosphere in the specific application.

IMPORTANT: If the size, model, or performance data of the sight flow indicator as received does not conform with any of the criteria above, do not proceed with installation. Contact an authorized ARCHON distributor for direction on what to do.

5.0 Installation

Use only qualified experienced personnel who are familiar with this equipment and thoroughly understand all the instructions in this manual for the installation of this equipment.

Refer to ARCHON dimension sheets or ARCHON product proposal to obtain dimensional information for the specific size and model sight flow indicator.

▲ **WARNING** ▲

Do not proceed with installation of a sight flow indicator unless:

1. **The glass has been examined and is free of scratches and other imperfections.** *Glass that is chipped or scratched is weakened and should not be used under any circumstances. Pressure/temperature ratings within chart above are no longer valid for glass that is weakened.*
2. **The connections and inside of the sight flow indicator have been cleaned and free of any foreign materials. Failure to do so can cause serious personal injury to personnel.**

Check the exploded view Figure 5 for the location of the inlet and outlet connections, and for the location and direction of the flow arrow to insure correct hook up.

5.1 Effect of Related Piping and Precautions

1. Do not impose system-piping loads on sight flow indicator. Unit is not designed to be a load-bearing component. Piping must be supported and aligned with sight flow indicator end connections to reduce the possibility of stresses imposed on the unit.
2. Locate the sight flow indicator where it can be easily seen.

3. Locate the sight flow indicator away from areas where objects may be dropped, thrown, or generally allowed to effect contact with the viewing window glass.
4. Locate the sight flow indicator so it is protected from dust, grit, tools, and any other objects, which may scratch, chip, or break the viewing window glass.
5. Locate the sight flow indicator so it is protected from external thermal shock, such as would be imposed on a unit in a high temperature application when exposed to a cold air blast or a cold water wash.

⚠ WARNING ⚠

Failure to mount, protect, and locate sight flow indicator as described within items 1 through 5 above may cause property damage or physical injury to personnel.

5.2 Positioning of Specific Models

1. Flapper models may be mounted in a horizontal plane provided the flapper closes over the inlet port by gravity when there is no flow.
2. Plain or rotator models may be mounted in any acceptable position.
3. Drip tube models should be mounted in a vertical plane with the flow arrow pointing downward.

5.3 Bolt Torque

IMPORTANT: Prior to any bolt torque checks, the sight flow indicator must be relieved of all pressure or vacuum, been allowed to reach ambient temperature, and been drained or purged of all fluids.

Bolt torque is vital to the proper operation of a sight flow indicator. Gaskets compress over a period of time; therefore, bolt torque should be checked, and bolt torque values should be brought up to those recommended in chart Figure 1 by following the bolt tightening sequence Figure 2.

Unit Size	Gasket Material			
	Viton [®] , Buna N, Neoprene		Teflon [®] , Asbestos, Grafoil [®] , Kel-F [®]	
	300# ANSI	600# ANSI	300# ANSI	600# ANSI
1/2" & 3/4"	6 - 7	9 - 11	8 - 10	14 - 16
1"	7 - 8	12 - 14	10 - 12	20 - 24
1 1/4" & 1 1/2"	8 - 10	14 - 16	12 - 14	23 - 27
2"	14 - 16	26 - 30	23 - 27	32 - 36
2 1/2" & 3"	28 - 32	58 - 62	47 - 51	90 - 94
4"	45 - 49	93 - 97	75 - 79	136 - 140
6" & 8"	93 - 97	181 - 185	129 - 133	272 - 276

Bolt Torque Values in Ft./Lbs.

Figure 1

6.0 Operation

6.1 Pre-Operational Check

1. Check that all installation procedures have been completed.
2. Check that bolts have been torques to their proper limits as stated within Section 5.3 Figure 1 above.

Bolt Tightening Sequence

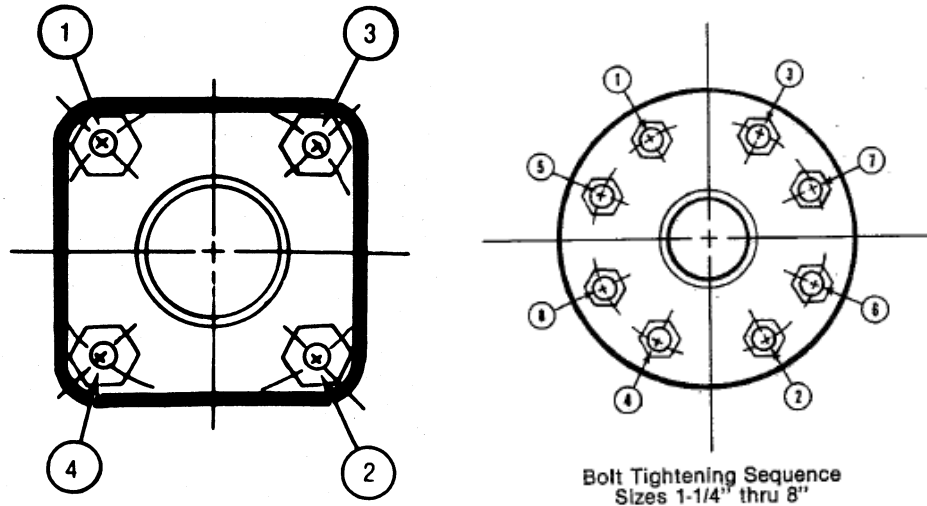

3. Check that glass is clean and free of any damage as described within Section 5. Installation above.
4. Check to determine that all connections are pressure tight.

6.2 Hydrostatic Pressure Test

1. Take all precautions necessary to handle the possibility of leakage.
2. Hydrostatic pressure test installation to at least 50 PSIG, and correct any leakage before proceeding.

6.3 Operating

⚠ WARNING ⚠

Sight flow indicator installations should be brought into service slowly to avoid excessive shock or stress on glass. Rapid pressurization of a sight flow indicator can cause glass breakage with resulting sudden release of pressure, causing serious personal injury to personnel.

IMPORTANT: Failure to bring a sight flow indicator slowly into service can result in property damage.

7.0 Maintenance

Use only qualified experienced personnel who are familiar with this equipment and thoroughly understand all instructions in this manual for all maintenance.

⚠ WARNING ⚠

DO NOT proceed with any maintenance unless the sight flow indicator has been relieved of all pressure or vacuum, has been allowed to reach ambient temperature, and has been drained or purged of all fluids. Failure to do so can cause serious personal injury to personnel.

7.1 Preventative Maintenance

Create maintenance schedules, safety manuals, and inspection details for each specific installation of a sight flow indicator.

On all installations, regularly check the following items for purposes of maintenance:

1. **Glass**, for cleanliness and signs of damage or wear.
2. **Shields**, if used, for signs of clouding, wear, or deterioration.
3. **Sight Flow Indicator**, for signs of leakage at gaskets, or at connections.
4. **Sight Flow Indicator**, for signs of internal or external corrosion.
5. **Bolt Torque Values**.

Determine upon evaluation of your own operating experience an appropriate maintenance schedule necessary for the specific application. Realistic maintenance schedules can only be determined with full knowledge of the services and application situation involved.

7.2 Maintenance Procedures

1. Glass

Regular and careful attention must be given to the cleaning and inspection of glass. *Glass that is etched or even slightly scratched is weakened and may break under pressure. Design ratings listed under Section 3.0 above are no longer valid for sight flow indicators that contain scratched, worn, or otherwise damaged glass, and such glass must be immediately replaced. Failure to do so can cause serious personal injury to personnel.*

- A. Keep glass clean using a commercial glass cleaner and a soft cloth. DO NOT use wire brushes, metal scraper, or any device which could scratch the glass.
- B. Inspect the surface of the glass for any signs of clouding, etching, scratching or physical damage such as bruises, checks, or corrosion that penetrates the outer surface of the glass. Shining a light at approximately a 45° angle will aid in detecting some of these conditions, which will glisten more brightly than the surrounding glass when reflecting light. Detection of any such problem areas or any surface wear is sufficient evidence of damage. Immediately take sight flow indicator out of service. DO NOT proceed with operation of sight flow indicator until the glass has been replaced with a glass replacement kit by following the disassembly-reassemble instructions under Section 7.4 below.

2. Shields

Shields, which show any signs of clouding, wear, or deterioration, are an indication that the sight flow indicator glass has been exposed, or could soon become exposed to the contained fluid. Immediately take sight flow indicator out of service. DO NOT proceed with operation of sight flow indicator until shields and glass have been replaced by following the disassembly-reassemble instructions under Section 7.4 below.

3. Gasket Leaks

Gasket leaks must be immediately repaired. DO NOT proceed with operation of a sight flow indicator until glass, gaskets and cushions have been replaced by following the disassembly-reassemble instructions under Section 7.4 below.

4. Connection Leaks

Leaks at a flanged or threaded connection should be corrected by tightening the bolts at the connection, or by taking the sight flow indicator out of service and remaking the connection with thread sealant tape or equivalent on all male pipe threads.

5. Corrosion

It is the user's responsibility to choose a material of construction compatible with both the contained fluid and surrounding atmosphere in the user's specific application. If internal or external corrosion is present, an investigation must immediately be carried out by the user as to the cause of the problem, including consulting with an authorized ARCHON distributor.

6. Bolt Torque

Bolt torque schedules should be developed by checking bolt torque values daily until an appropriate cycle becomes apparent. The maximum torque is always maintained while not exceeding maximums at any time as shown in chart Figure 1.

7.3 Troubleshooting for Soundness of Glass

Problem: Glass or shield becomes etched or clouded in service.
Cause: Fluid being handled is not compatible with the glass or shield material.
Cure: Install shields that are unaffected by fluid.

Problem: Glass continually breaks in service.
Cause: Warped body as a result of mechanical or thermal stresses.
Cure: Replace sight flow indicator.

7.4 Removal-Disassembly-Reassembly

⚠ WARNING ⚠

DO NOT proceed with the removal or disassembly of sight flow indicator from the connecting piping unless sight flow indicator has been relieved of all pressure or vacuum, has been allowed to reach ambient temperature, and has been drained or purged of all fluids. Failure to do so can cause serious personal injury to personnel.

1. Disassembly

A. Sight flow indicators should be disassembled by holding sight flow indicator firmly and loosening bolts by following the bolt loosening sequence shown in Figure 4.

Bolt Loosening Sequence

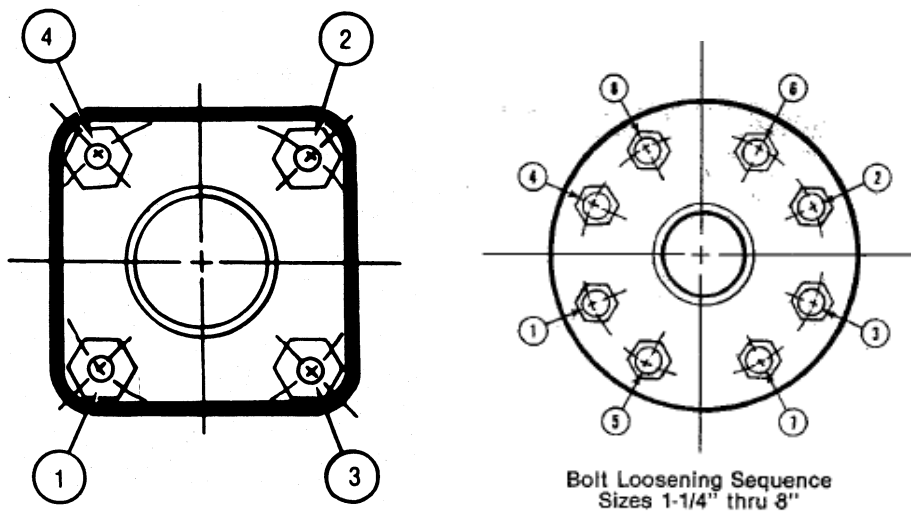

Figure 4

⚠ WARNING ⚠

Once sight flow indicator has been disassembled, all glass, gaskets, cushions, and shields (where used) must be disposed of since they are permanently deformed by compression. **DO NOT** under any circumstances re-use those items since they can cause leaks or high stress points resulting in glass breakage. If re-used, the glass can break causing serious personal injury to personnel.

2.Reassembly

A. Refer to exploded view, Figure 5.

- B. Prepare for installation of new glass (48) by first cleaning the gasket seating surfaces on body (11) and the cushion seating surfaces on the glass covers (1). This should be done using a soft metal scraper (preferably brass) to remove all burrs, rust, and bits of old gasket or cushion which may be present. Exercise extreme care to avoid gouging or scarring gasket or cushion seating surfaces.

⚠ WARNING ⚠

Failure to prepare gasket or cushion seating surfaces as described above can result in gasket leaks or glass breakage with resulting property damage or injury to personnel.

- C. Upon receipt of glass, inspect each piece individually for shipping damage. During inspection, and during any subsequent handling of glass, care must be exercised to keep glass (especially the polished faces) from contacting each other or any other surfaces including table tops. If shipping damage is evident or suspected, notify carrier immediately and request a damage inspection. Glass should be kept in original wrap within original box until ready to use.

⚠ WARNING ⚠

Bumping or sliding of glass against each other or against other surfaces can result in glass breaking, scratching, or chipping. Glass that is broken is dangerous and useless and should be disposed of in a safe manner determined by the user. Glass that is chipped or scratched is weakened and should not be used under any circumstances. Pressure/temperature ratings within Section 3.2 chart above are no longer valid for glass that is weakened. Failure to do so can cause serious personal damage to personnel.

- D. Place the sight flow indicator in a horizontal position and assemble the components as shown in exploded view Figure 5. Install band (331) around glass and place glass centered within the body and cover.
- E. Threads on bolts (137) and nuts (4) must be clean of paint, rust, and scale. Apply a light coat of oil to the threads and insert bolts through nameplate and two (2) covers, and install nuts finger tight.
- F. Use a torque wrench to tighten the bolts. Tighten bolts in increments of 3 ft./lbs. or 50% of torque value as shown in Figure 1 chart, whichever is smaller. Continue tightening sequence at 3 ft./lbs. max. torque until torque values in chart Section 3.3 Figure 1 are reached.
- G. Gaskets will become compressed a short time after bolts are tightened and torque values will decrease. Therefore, the sight flow indicator must be re-torque after 24 hours in service to values established within chart Figure 1 for the specific model sight flow indicator.

⚠ WARNING ⚠

DO NOT re-torque a sight flow indicator while under pressure. A sight flow indicator in service must be freed of all pressure or vacuum, allowed to reach ambient temperature and been drained or purged of all fluids before re-torquing is performed. Failure to follow this procedure can result in serious personal injury to personnel.

IMPORTANT: Re-torquing a sight flow indicator under pressure can result in property damage.

- H. Refer to Section 3.0 and 4.0 operation when returning sight flow indicator to service.

8.0 Telephone Assistance

If you are having difficulty with your Sight Flow Indicator, notify ARCHON INDUSTRIES, INC., (845) 368-3600. To help us assist you more effectively, please have model number and Purchase Order number available.

RECOMMENDED SPARE PARTS

REF. NO.	ITEM	QTY.
7	Gasket	2
48	Glass	2
8	Cushion	2
9*	Shield	2

*Shields are optional

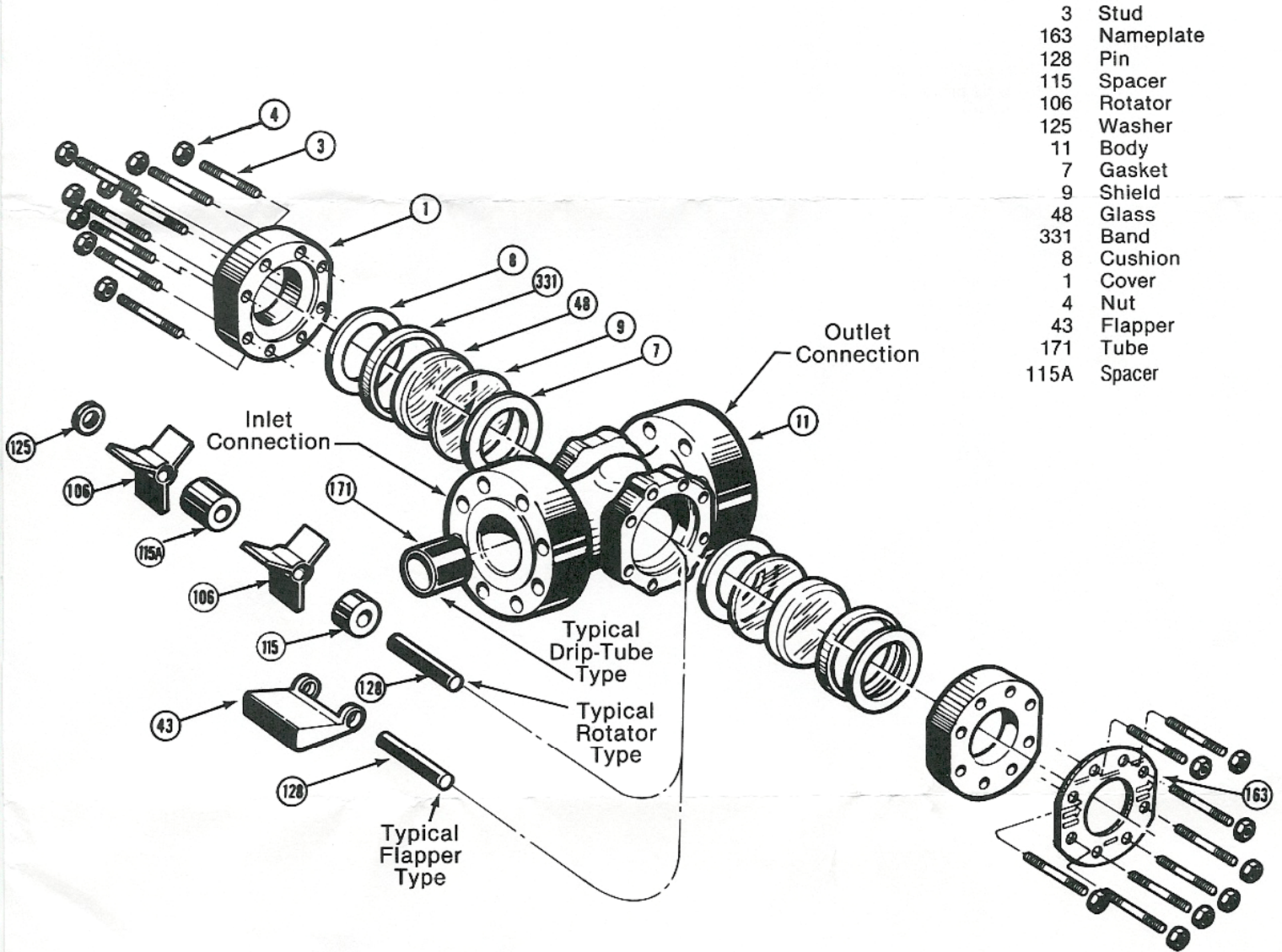

Figure 5