



ARCHON Industries, Inc.

## Armored Gauge O S & Y Bolted Bonnet Valves

### Series BB-100



## INSTALLATION / OPERATION / MAINTENANCE INSTRUCTION

May 3, 2012

Instr. # 1012 Rev A

Approved: F. Bongiorni, Engineering Manager

1



# **TABLE OF CONTENTS**

# **PAGE**

<b>Product Warranty</b>	3
<b>1.0 About the Manual</b>	4
<b>2.0 Introduction</b>	4
2.1 System Description	4
<b>3.0 Available Models</b>	5
3.1 Design Ratings	5
3.2 Steam Application	5
<b>4.0 Inspection</b>	5
4.1 User Rating Inspection	6
<b>5.0 Installation</b>	6
5.1 Piping Strain	6
5.2 Differential Thermal Expansion	6
5.3 Mounting	6
<b>6.0 Operation</b>	7
<b>7.0 Maintenance</b>	8
7.1 Preventive Maintenance	8
7.2 Ball Check Shutoff	8
7.3 Troubleshooting	9
<b>8.0 Removal / Disassembly / Re-assembly</b>	9
8.1 Disassembly	9
8.2 Re-assembly	10
<b>9.0 Disposal at End of Useful Life</b>	10
<b>10.0 Telephone Assistance</b>	11
<b>11.0 Parts Drawings</b>	12, 13



# PRODUCT WARRANTY

ARCHON Industries, Inc. warrants its products as designed and manufactured by Archon to be free of defects in material and workmanship for a period of one year after the date of installation or eighteen months after the date of manufacture, whichever is earliest. Archon will, at its option, replace or repair any products, which fail during the warranty period due to defective material or workmanship.

Prior to submitting any claim for warranty service, the owner must submit proof of purchase to Archon and obtain written authorization to return the product. Thereafter, the product shall be returned to Archon in Port Chester, New York, with freight prepaid.

This warranty shall not apply if the product has been disassembled, tampered with, repaired or altered outside of the Archon factory, or if it has been subjected to misuse, neglect or accident.

Archon's responsibility hereunder is limited to repairing or replacing the product at its expense. Archon shall not be liable for loss, damage, or expenses directly or indirectly related to the installation or use of its products, or from any other cause or for consequential damages. It is expressly understood that Archon is not responsible for damage or injury caused to other products, building, property or persons, by reason of the installation or use of its products.

THIS IS ARCHON'S SOLE WARRANTY AND IN LIEU OF ALL OTHER WARRANTIES, EXPRESSED OR IMPLIED WHICH ARE HEREBY EXCLUDED, INCLUDING IN PARTICULAR ALL WARRANTIES OF MERCHANTABILITY OR FITNESS FOR A PARTICULAR PURPOSE.

This document and the warranty contained herein may not be modified and no other warranty, expressed or implied, shall be made by or on behalf of Archon unless modified or made in writing and signed by the President or a Vice President of Archon.



## 1.0 About the Manual

This manual has been prepared as an aid and a guide for personnel involved in installation or maintenance. All instructions must be read and understood thoroughly before attempting any installation, operation, or maintenance. Failure to follow *any* instruction could possibly result in a malfunction of the gage, breakage with resulting sudden release of pressure, property damage or physical injury to personnel.

## SAFETY INSTRUCTIONS

**Archon does not have any control over the manner in which its liquid level gage is handled, installed or used. Archon cannot and will not guarantee that a liquid level gage is suitable or compatible for the user's specific application.**



**WARNING**



**Contained fluids may be pressurized and can unexpectedly exit vessel connections due to apparatus or material failure. Safety glasses should be worn when installing a liquid level gage. Failure to do so could result in serious physical injury to personnel.**

## 2.0 Introduction

Archon armored liquid level gage valves are used to isolate gauge glass, magnetic gauges or other apparatus from the vessel when it becomes necessary to drain or service the gauge. The series **BB-100** Forged Steel O.S. & Y Bolted Bonnet Gauge Valves are off-set type, have a forged yoke and a separate follower packing gland to compress the stem packing. This design places the threaded portion of the valve stem outside of

the body to prevent contact with the process fluid. The valve stem is a reciprocating non-rotating stem.

Valves are supplied in pairs (upper and lower), and are available with flanged or threaded connections. These valves are optionally equipped with ball check shut-offs to prevent leakage of contained fluid in case of accidental gauge glass breakage.

## 2.1 System Description

Archon gauges are comprised of six basic components. Each component may vary slightly, depending on the desired physical and mechanical properties for the gage. Use the exploded parts view in Section 11 as additional reference material.

Body- a pressure retaining structure through which liquid passes to enter a gage glass or other apparatus. Provides a rigid connection to the vessel.

Yoke- seals and supports the stem and stem packing during operation. The yoke contains the stem packing to prevent valve leakage. The yoke is sealed with a gasket as it is compressed against the valve body using screws. Threads in the yoke provide the torsional base that acts upon the stem when the valve is opened and closed.

Ball Checks- sphere installed loosely within the body of the valve that seats to prevent significant leakage when a differential pressure surge occurs (e.g. mechanical failure).

Trim- wetted parts that mechanically control the liquid path from the vessel to the gage glass or other apparatus. The ball and stem act to seal and release the liquid. In the event of mechanical failure, the ball will seat to prevent large quantities of the contained fluid from exiting the vessel. Liquid is allowed to exit the vessel into the gage glass or other apparatus when the stem is screwed away

4

from its sealed position. The liquid is sealed when the stem is screwed into its seated position.

The stem packing retainer provides a compression surface between the process liquid and the stem packing. A stem packing gland is used to compress the packing against the retainer and around the stem to prevent leakage.

Stem Packing- under compression the stem packing is forced to mold around the stem and prevent leakage of media during operation.

Gage Connection- provides connection between the valve and the gage glass or other apparatus. A packing gland, union, spherical union or rigid connection may be used.

Handwheel/Lever- rotated to engage threads and provide screw action of stem.

### 3.0 Available Models



**DANGER**

**NOTE:**  
**NEVER** exceed these design ratings or application data. Exceeding design ratings or application data may result in mechanical failure of gauge components resulting in death, serious personal injury and property damage.

- Model Vessel/ Gage Connection
- BB-101 Male NPT Plain/ Female NPT Plain
- BB-121 Male NPT Plain/ Female NPT Union
- BB-131 Male NPT Plain/ Fem NPT Spherical Union
- BB-141 Male NPT Plain/ Stuffing Box, 5/8" or 3/ 4"OD
- BB-151 Male NPT Plain/ Male NPT Union
- BB-161 Male NPT Plain/ Male NPT Spherical Union

### 3.1 Design Ratings

3000 psig at 100°F / 1200 psi at 600°F  
Exception: Model BB-141 (stuffingbox) 550 psi at 500°F

### 3.2 Steam Application

Archon series BB-100 valves with stuffing box may be used in low pressure steam/water applications (<=550 psig saturated steam pressure). The stuffing box is secured to the valve body with a coupling nut; a special nipple extends from the gage to the stuffing box where packing is compressed around the nipple. The gage rests on the bottom valve while the coupling nuts are tightened.

### 4.0 Inspection

Upon receipt of a gage valve set, check all components carefully for damage incurred in shipping. If damage is evident or suspected, do not attempt installation. Notify carrier immediately and request damage inspection. Refer to exploded view drawing in Section 11.0 to inventory parts.

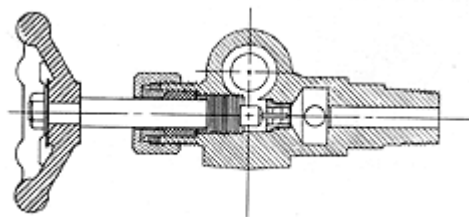

### BB-100 series OS&Y

Available Connection Configurations:

### 4.1 User Rating Inspection



The user should confirm that:

1. The gage valve set model number and pressure/temperature rating stamped on conforms to the description on the user's purchase order.
2. The operating conditions described in the purchase order agree with the actual operating conditions at the installation site.
3. The actual operating conditions at the installation site are within the applications data shown on the Archon Technical Data Bulletin or product proposal referred to previously.
- 1) The materials of construction of the gage valve set are compatible with both the contained fluid and the surrounding atmosphere in the specific application.

## SAFETY INSTRUCTIONS

**If the size, model or performance data of the gage valve set as received does not conform to any of the criteria above, do not proceed with installation. Contact an authorized Archon Distributor for assistance. The incorrect gauge can result in unacceptable performance and potential damage to the gauge.**

### 5.0 Installation

Only qualified personnel who are familiar with this equipment should undertake installation. They should have read and understood all the instructions in this manual. The user should refer to Archon dimension sheets or Archon product proposal to obtain dimensional information for specific size and model gage valve.

Archon recommendations on gage valve installations are not necessarily related to the installation of the glass liquid level gages. The number of different types of gage and valve installations is too great to adequately explain in an installation manual. Therefore, it is the user's

responsibility to assure that knowledgeable installation personnel plan and carry out the installation in a safe manner. The following procedures are some of the guidelines that should be employed.

#### 5.1 Piping Strain

The gage valve should be mounted and connected so that it can support the gage without binding. Torsional stresses can make it difficult or impossible to seal tailpipes. Although union connections will allow marginal errors in piping alignment, misalignment can still create unusual strain on connectors. Gages not properly supported by brackets may subject the gage valve to stresses that can cause leaks or mechanical failure.

#### 5.2 Differential Thermal Expansion

High mechanical loading may be imposed on a gage valve by expanding and contracting gages due to hot or cold service. Such mechanical loads on the valve must be minimized by the use of expansion loops or stuffing boxes. Failure to allow for expansion or contraction can result in leaks or mechanical failure.

#### 5.3 Mounting

1. Prior to installation, turn the handlewheel of each valve clockwise until the stem closes against the seat.

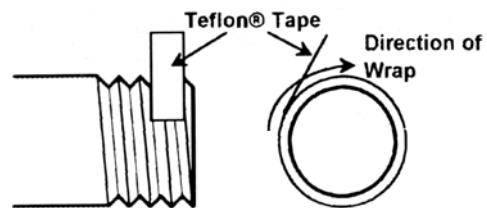

FIGURE 1

2. Mount upper and lower valves to the vessel using Teflon tape or equivalent on all male tapered pipe thread connections, as shown in Figure 1. If the valve is

flanged mount, use proper industry standard procedures.

3. If installing with a flat glass gage, follow all installation instructions for the specific liquid level gage as there are many points to consider on gage installation; among them, piping strain, differential thermal expansion, weight and bolt torque.
4. Install gages tailpipes to union gage connections, where applicable, making sure that the coupling nuts are in place.

the instructions. Check to determine that all connections are pressure tight.

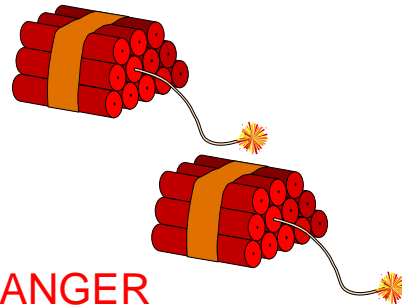

**Valve installations should be brought into service slowly. Valves should be opened slightly, and the valve assembly temperature and pressure allowed to slowly equalize. If the valves are equipped with ball checks, the valves must be opened all the way after the pressure and temperature have equalized to permit operation of the automatic ball check in the event of failure. Failure to follow the recommended operating procedures can result in severe personal injury and property damage.**

#### 5.4 Stuffing Box

1. Install tubular packing nut, tubular packing gland and tubular packing to each end of the gage connection.
2. Loosen the upper valve vessel connection counterclockwise by approximately 1/8 turn.
3. Insert the top end connection of the gage into the upper valve stuffing box connection as far as it will go.
4. While holding the gage in position in the upper valve packing gland with upward force to ensure it clears the lower valve connection, return the upper valve back to its original position by rotating back the 1/8 turn rotated in step 2 above.
5. Slide the gage assembly down into the lower valve stuffing box connection until it bottoms. Tighten the upper and lower valve tubular packing nuts.

#### 6.1 Hydrostatic Test

Take all precautions necessary to handle the possibility of leakage during the test. Hydrostatic pressure test all installations to 100psig [689 kPa] and correct any leakage before proceeding.

#### **6.0 Operation**

Before initializing gage valve operation, check that all installation procedures have been completed. Use only qualified experienced personnel who are familiar with valve equipment and thoroughly understand the implications of the tables and all

## 7.0 Maintenance



Use only qualified, experienced personnel who are familiar with valve equipment and thoroughly understand the implications of the tables and all the instructions. DO NOT proceed with any maintenance unless the valve assembly has been relieved of all pressure or vacuum, has been allowed to reach ambient temperature, and has been drained or purged of all fluids. Failure to do so can cause serious personal injury and property damage.

The user must create maintenance schedules, safety manuals, and inspection details for each gage valve. These will be based upon the users own operating experience with their specific application. Realistic maintenance schedules can only be determined with full knowledge of the services and application situations involved.

During system shutdown, the valves should be left open to permit the gage to lose pressure and cool with the rest of the system. Failure to leave the valve open during system shutdown may trap high pressure fluid in the gage.

### 7.1 Preventive Maintenance

On all installations the following items should be regularly evaluated by the user for purposes of maintenance:

1. Leakage around stem area
2. Internal stem leak
3. Leakage around union connections
4. Internal or external corrosion
5. Leakage between the body and the yoke

The user must determine upon evaluation of his or her own operating experience an appropriate maintenance schedule necessary for his or her own specific application. Realistic maintenance schedules can only be determined with full knowledge of the services and application situation involved.

### 7.2 Ball Check Shut-Off

#### **SAFETY INSTRUCTIONS**

**Ball checks, when installed, may fail to seat due to corrosion of the ball or seat, foreign material in ball chamber or viscous material in the ball chamber. A routine operational test of the ball check can prevent significant seepage of liquid in the event of glass breakage.**

**An operational check can be performed on the valve ball checks by closing both the upper and lower valve stems completely. Drain contents from and relieve pressure on liquid gage to an appropriate safe container/area. NOTE: some loss of process fluid to the drain line is expected with this test procedure.**



Use only qualified, experienced personnel who are familiar with valve equipment and thoroughly understand the implications of the tables and all the instructions. DO NOT proceed with any maintenance unless the valve assembly has been relieved of all pressure or vacuum, has been allowed to reach ambient temperature, and has been drained or purged of all fluids. Failure to do so



can cause serious personal injury and property damage.

With drain line still in place, open **BOTTOM** valve as rapidly as possible. Listen for “click” sound which will indicate that the ball has seated. If possible, observe the quantity of flow from the drain line. Flow should either stop completely or be no greater than single drips (no solid stream). Close lower valve. Repeat above procedure for **UPPER** valve. There must be a pressure differential of at least 5psi [34.5 kPa] for the above procedure to work properly.

If the above procedure is not successful, the only alternative is to isolate the gage and valve assembly from the vessel or to shut the process down completely. Disassemble the valve as outlined in Section 8.1 using the exploded parts drawing in Section 11.0 as reference. Visibly inspect ball check and ball seats in the valve body. Remove any foreign matter and/or replace with new ball checks if inspection indicates this is required. If the ball seat is damaged, consider replacing the valve or the seat (if it is removable). Reassemble valves as outlined in Section 8.2

### 7.3 Troubleshooting

**STEM PACKING LEAKAGE** can often be stopped by tightening the stem packing nut. If leak persists, the stem packing should be replaced by following steps 1-5 of the Disassemble and 1-6 of the Reassemble instructions.

**INTERNAL SEAT LEAKAGE** is an indication of a worn or damaged stem or seat. To replace the stem follow steps 1-5 of the Disassembly and 1-7 of the Reassembly instructions. To replace the threaded seats of the series 700, insert hex key in the seat, and turn it counterclockwise. To replace the threaded seats of the series 900 and BB-100, insert socket head driver over the seat, and turn it counterclockwise.

Replace the new seat by turning it clockwise, making sure that the ball check, if used, is replaced in the body. Tighten the seat in place. Follow steps 4 and 5 of the Reassembly instructions.

**LEAKAGE AROUND UNION** connections can often be stopped by tightening union coupling nut or remake connection using Teflon tape, or equivalent, on all male pipe threads as shown in Figure 1.

**INTERNAL OR EXTERNAL CORROSION** could be an indication of a misapplication. An investigation should immediately be carried out to determine the cause of the problem. It is the user's responsibility to choose a material of construction compatible with both the contained fluid and the surrounding atmosphere.

**Tightening the yoke screws can often stop LEAKAGE BETWEEN BODY AND YOKE.** If the leak persists, the yoke gasket should be replaced by following steps 1, 2 of the Disassembly Procedures and 4, 5 of the Reassembly Procedures.

### 8.0 Removal – Disassembly – Reassembly



**Use only qualified, experienced personnel who are familiar with liquid level gauge equipment and thoroughly understand the implications of the tables and all the instructions. DO NOT proceed with any maintenance unless the liquid level gauge has been relieved of all pressure or vacuum, has been allowed to reach ambient temperature and has been drained or purged of all fluids. Failure to do so can cause serious personal injury and property damage.**

### 8.1 Disassembly

Refer to the parts drawing in Section 11.0 for additional reference during

9

assembly and reassembly of the valves.

1. Loosen and remove the yoke screws. Slide yoke assembly from the body.
2. Remove the yoke gasket.
3. Remove the handwheel nut, washer, nameplate and handwheel.
4. Remove the stem from the yoke by pulling it through the stem sleeve and yoke.
5. Remove the stem packing retainer, packing, packing gland.
6. For valves equipped with a stuffing box connection
  - a. loosen the tubular packing nut on both upper and lower valves.
  - b. slide the gage assembly into the upper valve as far as it permits.
  - c. while holding the gage in this upward position, rotate the upper valve counterclockwise approximately 1/8 turn to allow clearance to remove the gage from the upper connection.
  - d. Remove the gage from the upper valve.
  - e. Remove the tubular packing nut, packing gland and packing from both the upper and lower valve.

## 8.2 Reassembly

Refer to the parts drawing in Section 11.0 for additional reference during assembly and reassembly of the valves.

1. Insure that the stem packing gland screws are loose enough to allow for the new stem packing.
2. Install stem packing retainer, new stem packing, packing gland and packing onto the stem. Slide the stem through the yoke and stem sleeve as far as it permits.
3. Place the nameplate, washer and handwheel on the end of the stem. Tighten in place with the handwheel nut.
4. Turn the handwheel counterclockwise as far as it will go, seating the stem

against the stem packing retainer. Install the new yoke gasket.

5. Mount the yoke assembly to the body and secure using the yoke screws. Tighten stem packing gland screws. NOTE: Yoke and stem packing gland screws should be tightened evenly to insure even compression.
6. For valve equipped with stuffing box connection:
  - a. place the tubular packing nut, packing gland and packing on each end of the gage connection.
  - b. With the upper valve turned 1/8 turn counterclockwise from the vertical, insert the top gage connection into the stuffing box connection of the upper valve. To insure clearance of the lower connection end, slide the gage up into the upper valve as far as it permits.
  - c. Tighten the upper valve to its original position while holding the gage with upward force to insure clearance of the lower valve stuffing box connection. Check vertical alignment of the valves.
  - d. Slide the gage assembly down into the lower stuffing box connection to a positive stop.
  - e. Tighten the tubular packing nut on both the upper and lower valve.

Refer to Section 6.0 for operation of the gauge valve when returned to service.

## **9.0 Disposal at End of Useful Life**

Archon valves are used in a variety of fluid applications. By following the appropriate governmental and industry regulations, the user must determine the extent of preparation and treatment and valve must incur before its disposal. A Material Safety Data Sheet (MSDS) may be required before disposal services accept certain components.

Metals and polymers should be recycled whenever possible. Refer to order and Archon's Material Specification sheets for materials of construction.

contacted before any repairs are initiated should the cost exceed the minimum charge. If you return a unit that is covered by the warranty, but is not defective, the minimum charge will apply.

### 10.0 Telephone Assistance

If you are having difficulty with your liquid level gage, notify ARCHON Industries, Inc. You may also contact the factory direct at (845) 368-3600 and ask for an applications engineer. So that we may assist you more effectively, please have as much of the following information as possible when you call:

- Model #
- Name of the company from whom you purchased your liquid level gage
- Invoice # and date
- Process fluid
- Operating pressures
- Operating temperatures
- A brief description of the problem
- Troubleshooting procedures that failed

If attempts to solve your problem fail, you may be requested to return your liquid level gage to the factory for intensive testing. You must obtain a Return Authorization (R.A.) number from ARCHON Industries, Inc. prior to returning anything. Failure to do so will result in the unit being returned to you, without being tested, freight collect. To obtain a R.A. number, the following information (in addition to that above) is needed:

- Reason for return
- Person to contact at your company
- "Ship To" address

We recommend that you return the entire unit for testing. There is a minimum charge of \$75.00 for evaluation of non-warranty units. You will be



# 11.0 Parts Drawings-

## BB-101 OS&Y valve 11.0 Parts Drawings- BB-121 OS&Y valve

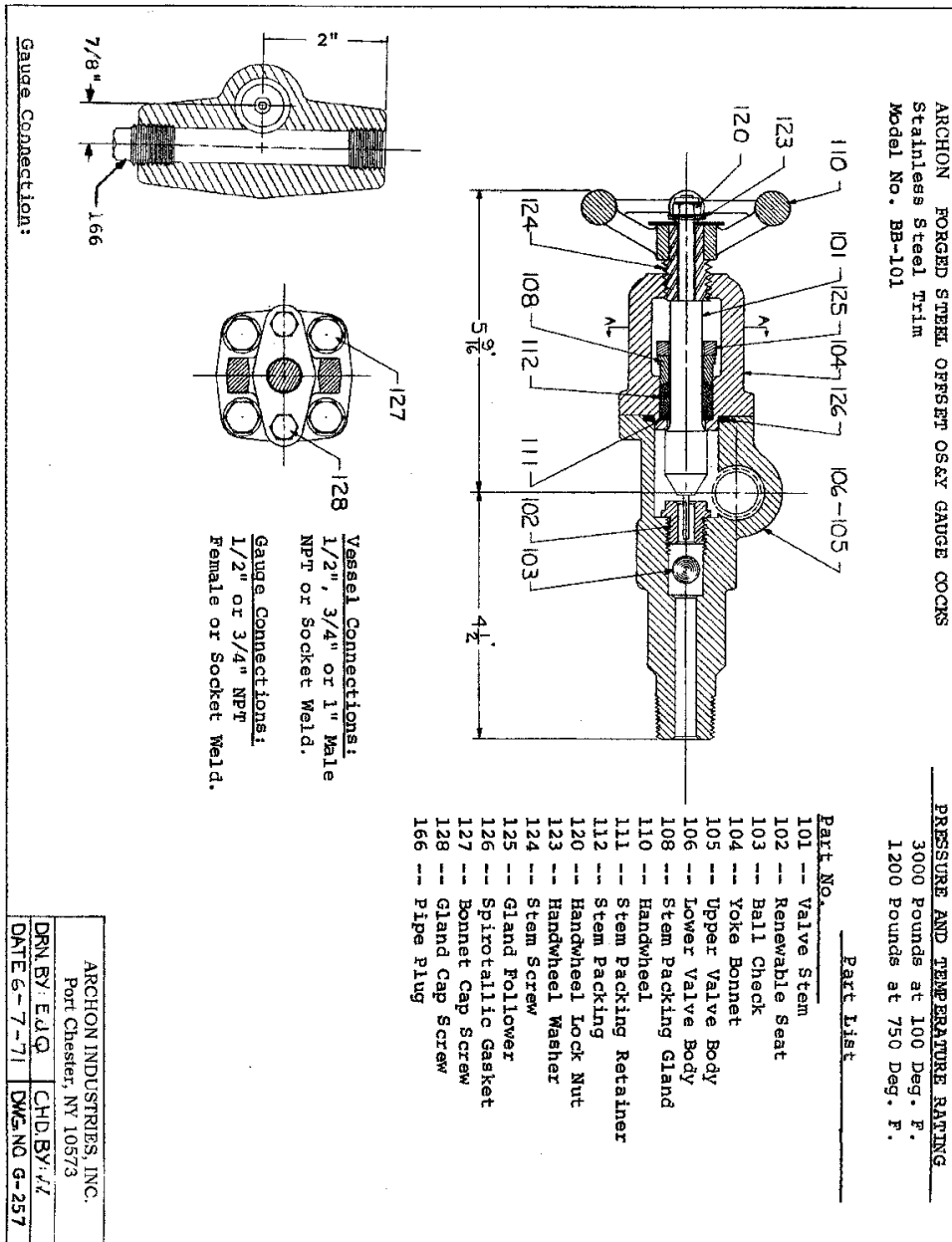

**ARCHON FORGED STEEL OFFSET OS&Y GAUGE COCKS**  
**MODEL NO. BB-121**  
**STAINLESS STEEL TRIM**

**PRESSURE AND TEMPERATURE RATING**  
 3000 POUNDS AT 100 DEG. F.  
 1200 POUNDS AT 750 DEG. F.

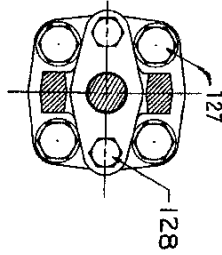
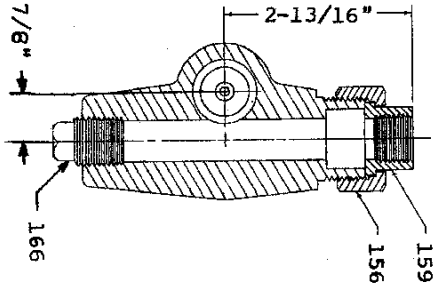
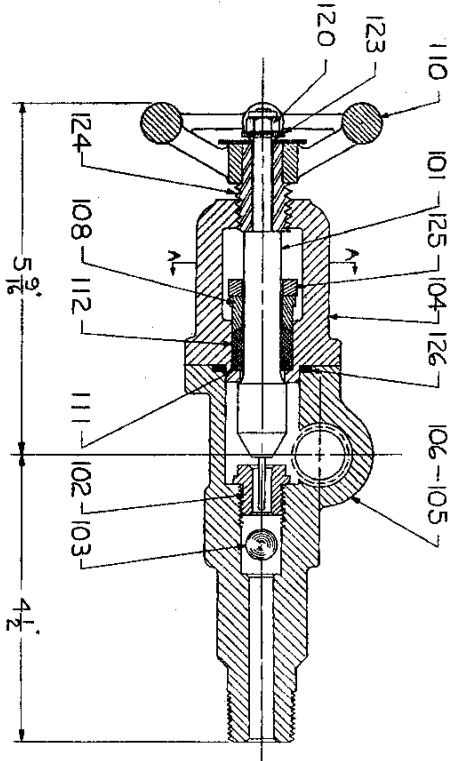

**VESSEL CONNECTIONS:**  
 1/2" OR 3/4" OR 1" MALE  
 NPT OR SOCKET WELD.  
**GAUGE CONNECTIONS:**  
 7/8" OR 3/4" NPT OR  
 SOCKET WELD FEMALE UNION.

**PARTS LIST**

PART NO.	DESCRIPTION
101	VALVE STEM
102	RENEWABLE SEAT
103	BALL CHECK
104	YOKE BONNET
105	UPPER VALVE BODY
106	LOWER VALVE BODY
108	STEM PACKING GLAND
110	HANDWHEEL
111	STEM PACKING RETAINER
112	STEM PACKING
120	HANDWHEEL LOCK NUT
123	HANDWHEEL WASHER
124	STEM SCREW
125	GLAND FOLLOWER
126	SPIROTALLIC GASKET
127	BONNET CAP SCREW
128	GLAND CAP SCREW
156	STANDARD UNION NUT
159	FEMALE UNION TAILPIECE
166	PIPE PLUG

GAUGE CONNECTION

**ARCHON INDUSTRIES, INC.**  
 Port Chester, NY 10573  
**DRAWING NO. G-258**

